

Quick Guide for EGT Application.

This meter is preset for EGT application. To operate it, connect 12 VDC to terminal 1 (+) and 2 (-). Connect the EGT sensor to terminal 6 (-) and 7 (+) as shown in Fig. 1. The meter is ready to run.

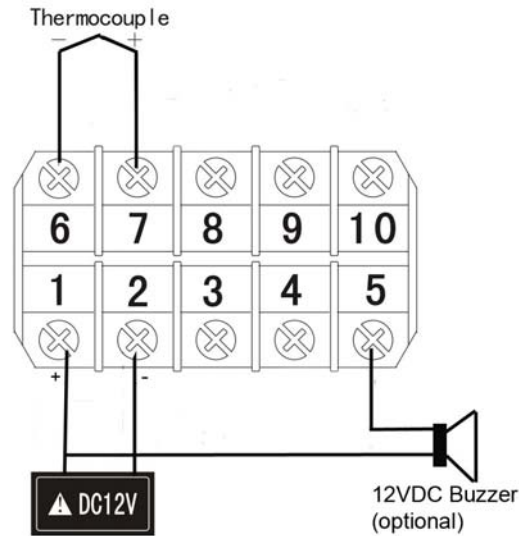

Fig 1. Wiring diagram

Application Tips.

- 1) The input is configured for K type thermocouple. Almost all EGT sensors on the market use K type thermocouple. The most common problem in connecting the sensor is wrong polarity. USA made EGT sensor uses red color for the negative lead. EGT sensors from other countries use red color for the positive lead (including Auber's sensor). If the polarity of the lead is reversed, the temperature reading will decrease as the engine warms up. Switch the leads between terminal 6 and 7 will correct this problem. Sensor will not be damaged if connected in wrong polarity.
- 2) The alarm is at 900 F. The AL LED will be on above that temperature. It will be off when temperature drops to below 800 F. To change the alarm, use code 0001 to change AH1 and AL1 setting. The detail can be found in section C 2 of the instruction manual.
- 3) The temperature display unit is for Fahrenheit. To change it to Celsius, use code 89 to change CorF setting. When temperature change from F to C, the alarm temperature needs to be reset to the corresponding value. The detail can be found in section C1 of the instruction manual.
- 4) The peak holding function is set for display the Maximum temperature. To display the peak temperature from the last run, or display the temperature in the peak holding mode continuously, press the ">" key once. The MAX (MIN) LED will be on, indicating the display is in the peak mode. Press ">" again to change back to display the current temperature. Press and hold "Λ" for 3 seconds will reset the memory. Three additional peak parameters have been turned off for this meter. They are, the time that the maximum temperature was recorded, the minimum temperature and its recording time. If you want to see them, use code 0037 to turn on these functions. The detail can be found in section C3 of the instruction manual.
- 5) Error message. If the meter displays "EEEE", it indicates the EGT sensor is not connected correctly or is faulty. To confirm the problem, you can short terminal 6 and 7 with a wire. If the meter displays the ambient temperature you can be 100% certain that the problem is due to the sensor.