

Quick Guide for Auber P205g Installation

A. Installation of Auber 205g, 5 bar (75psi) transducer.

1) Wiring the sensor as shown in Fig 1. Connecting power lead (red) to terminal 10, signal lead (green) to terminal 9, and ground lead (black) to terminal 6. The 12V DC buzzer is optional.

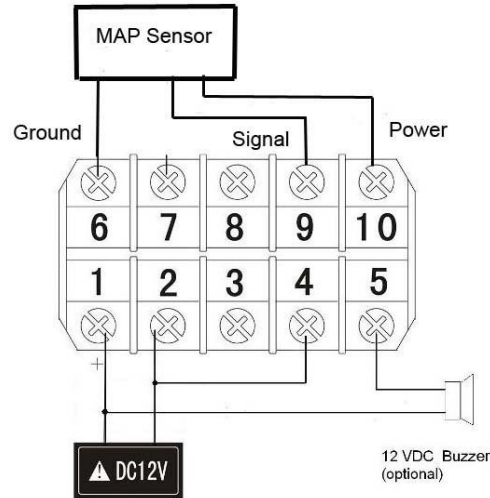

Fig 1. Wiring diagram for SYL-1813 automobile multimeter.

2) To display the gauge pressure unit in PSI (0.1psi resolution), enter the Basic Parameter setting mode with code 0089, a) Set input type, **Inty**, for 0-5 V input. b) Set the decimal point, **dot**= 000.0. c) Set the PuL = -09.4. PuH = 084.4.

3) To display the gauge pressure unit in Bar (0.01 bar resolution), enter the Basic Parameter setting mode with code 0089, a) Set input type, **Inty**, for 0-5 V input. b) Set the decimal point, **dot**= 00.00. c) Set the PuL= -0.65. PuH = 05.82.

4) To set the alarm on at 50 psi and off at 49 pis, Enter code 0001 to set AH1 = 050.0 and AL1=049.0. The detail can be found in section C 2 of the instruction manual.

5) Zero Adjustment. If the pressure does not show 0.00 bar or 0.0 psi when no pressure is applied, you can adjust the display to zero by shifting the value of PuL and PuH for the same amount. e. g. if the display shows 0.5 psi when no pressure is applied to the sensor, you can minus 0.5 from PuL and PuH. Set PuL to -08.9 (-9.4 - 0.5 = -8.9), and PuH 083.9 (84.4 - 0.5 = 83.9). Please note that the overall accuracy of the sensor is 1.5% of full scale. It is normal to see the zero point to fluctuate slightly.

B, Discussion

1) If you want the display to display a different pressure unit than Bar or PSI, you need to find the value of PuL and PuH. Appendix 1 shows how the Auber P205g sensor parameter is determined. If you need help, please email us the specification of your sensor to info@auberins.com

2) The peak holding function is set for displaying the Maximum pressure only. To display the peak pressure from the last run, or display the pressure in the peak holding mode

continuously, press the “>” key once. The MAX (MIN) LED will be on, indicating the display is in the peak mode. Press “>” again to change back to display the current pressure. Press and hold “Λ” for 3 second will reset the memory. Three additional peak parameters are turned off. They are, the time that the maximum pressure was recorded, the minimum pressure and its recording time. If you want see them, use code 0037 to turn on these functions. The detail can be found in section C3 of the instruction manual.

C. Appendix 1,

Example, Calculating the set up parameters for Auber 205 sensor.

For a pressure sensor that is powered by 5 V DC, the linear range of the output signal will be higher than 0V and lower than 5 V due to the nature of mechanics and electronics. For this sensor 0 psi = 0.50V, 75 psi =4.5V. What these data tell us is that the sensor has a linear output between 0.5 and 4.5 V when the input signal is between 0 and 75 psi, In other words, within this range, the relationship between pressure and output voltage can be represented by

$$V = a \times P + b \quad (1)$$

Where P is the pressure, V is the voltage. **a**, is the slop, and **b** is the intersection at zero pressure,

Because the meter is set for 0-5V linear input, we need to find out what is the pressure when we extend the equation (1) from 0.5-4.5V to the 0 ~5 V range. The pressure at 0 and 5 V output will be used to set the meter display scale.

Calculating slop **a** and intersection **b**

$$a = (4.5 - 0.5) / (75) = 0.0533$$

$$b = V - a \times P = 0.5$$

$$\text{So, } V = 0.0533P + 0.5, \text{ or } P = (V - 0.5) / 0.0533$$

Therefore, at 0 V, P = -09.4 PSI; at 5 V, P = 84.4 PSI.

To display in pressure in bar unit,

Set **dot** to **00.00**, **PuL** = **-0.65**, **PuH** = **5.82**

Please note, numbers used in the meter set up (page 1) may be slight different than this number. They were corrected by actual calibration with the meter for better accuracy.