

Fuel/oil Pressure Transducer Installation Guide

A. Installation of Auber P218 oil/fuel transducer

1) Wiring the sensor as shown in Fig 1. Connecting power lead (red or brown) to terminal 10, signal lead (green or blue) to terminal 9, and ground lead (black) to terminal 6. The 12V DC buzzer is optional.

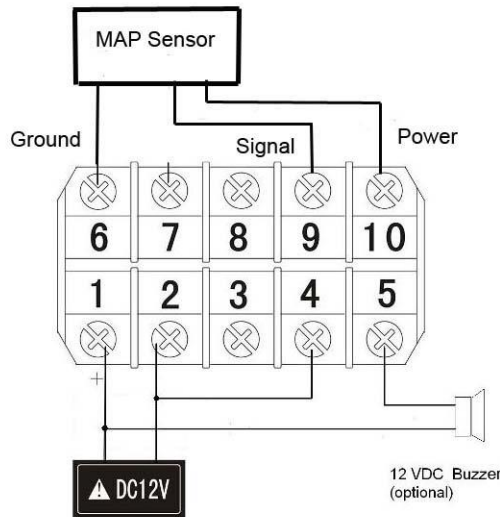

Fig 1. Wiring diagram.

2) To display the pressure unit in PSI (1psi resolution), enter the Basic Parameter setting mode with code 0089, a) Set input type, **Inty**, to 5_V for 0-5 V input. b) Set the decimal point, **dot**= 0000. c) Set the PuL = -033 PuH = 0294.

3) To display the pressure unit in Bar (0.1 bar resolution), enter the Basic Parameter setting mode with code 0089, a) Set input type, **Inty**, to 5_V for 0-5 V input. b) Set the decimal point, **dot**= 000.0. c) Set the PuL= -02.3. PuH = 020.3.

4) To set the alarm on at 16.5 Bar and off at 16.4 Bar, Enter code 0001 to set AH1=16.5 and AL1=16.4. The detail can be found in section C 2 of the instruction manual.

5) Zero Adjustment. If the pressure does not show 0.0 bar or 0 psi when no pressure is applied, you can adjust the display to zero by shifting the value of PuL and PuH for the same amount. e. g. if the display shows 3 psi when no pressure is applied to the sensor, you can minus 3 from PuL and PuH. Set PuL to -036 (-33-3=-36), and PuH 0291 (294-3=291). Please note that the overall accuracy of the sensor is 1.5% of full scale. It is normal to see the zero point to fluctuate slightly.

B, Discussion

1) The peak holding function is set for displaying the Maximum pressure only. To display the peak pressure from the last run, or display the pressure in the peak holding mode continuously, press the ">" key once. The MAX (MIN) LED will be on, indicating the display is in the peak mode. Press ">" again to change back to display the current pressure. Press and hold "Λ" for 3 second will reset the memory. Three additional peak

parameters are turned off. They are, the time that the maximum pressure was recorded, the minimum pressure and its recording time. If you want see them, use code 0037 to turn on these functions. The detail can be found in section C3 of the instruction manual.

2) If you want the meter to display a pressure unit that is not Bar or PSI, or if you have a pressure sensor (sender, transducer or transmitter) that has different output specification, you need to find the value of PuL and PuH. Appendix 1 shows how the Auber P218 sensor parameter is determined. If you need help, please email us the specification of your sensor to info@auberins.com

C. Appendix 1,

Example, how to determine the set up parameters for Auber P218 transducer.

For a pressure sensor that is powered by 5 V DC, the linear range of the output signal will be above 0V and less than 5 V due to the nature of mechanics and electronics. Auber P218 published data. 0 bar = 0.5V, 10 bar =4.5 V. What these data tell us is that the sensor has a linear output between 0.5 and 4.5 V when the input signal is between 0 and 18 Bar, In other words, within this range, the relationship between pressure and output voltage can be represented by

$$V = a \times P + b \quad (1)$$

Where P is the pressure, V is the voltage. **a**, is the slop, **b** is the intersection at zero pressure,

Because the meter is set for 0-5V linear input, we need to find out what is the pressure when we extend the equation (1) from 0.50-4.50V to the 0 and 5 V.

Calculating slop **a** and intersection **b**

$$a = (4.50 - 0.50) / (18 - 0) = 0.22$$

$$b = 0.50$$

$$\text{So, } V = 0.22P + 0.5, \text{ or } P = (V - 0.50) / 0.22$$

Therefore, at 0 V, P = -2.25; at 5 V, P = 20.27.

To display pressure in Bar,

Set dot to 000.0, PuL=-2.3, PuH=20.3

To display the pressure with PSI units instead of Bar, multiply the number by 14.5
(1bar=14.503PSI)

Set dot to 0000, PuL=-33, PuH=294.