

Quick Guide for Auber PV-1 Installation

V 1.2

A. Installation of Auber PV-1, -1 bar (-14.5 PSI) to 0 bar transducer.

1) SYL-1813 wiring the sensor as shown in Fig 1a. Connecting power lead (red) to terminal 10, signal lead (blue) to terminal 9, and ground lead (black) to terminal 6. The 12V DC buzzer is optional.

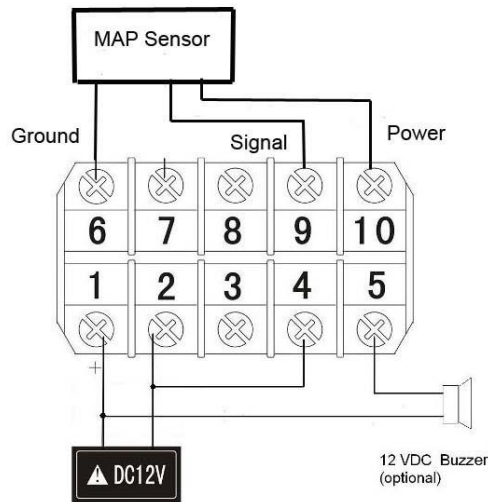

Fig 1a. Wiring diagram for SYL-1813 automobile multimeter.

SYL-2342: wiring the sensor as shown in Fig 1b. Connecting power lead (red) to terminal 4, signal lead (blue) to terminal 2, and ground lead (black) to terminal 5.

Model SYL-2342Y

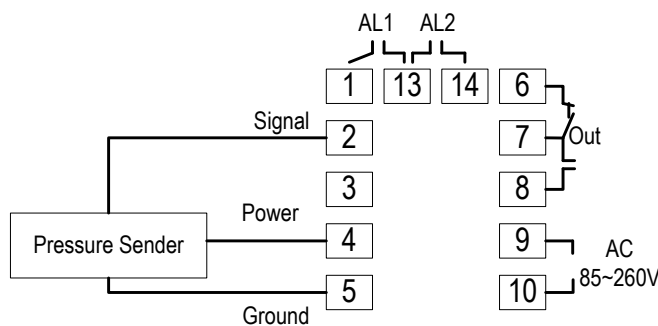

Fig 1b. Wiring diagram for SYL-2342Y

2) To display the gauge pressure unit in PSI (0.1psi resolution, 0 for atmosphere pressure, -14.5 PSI for max vacuum),
 For SYL-1813, enter the Basic Parameter setting mode with code 0089, a) Set input type, **Inty**, for 0-5 V input. b) Set the decimal point, **dot= 000.0**. c) Set the PuL = - 16.3. PuH = 1.8.
 For SYL-2342Y, set dp=1, P-SL = -16.3. P-SH =1.8

Auber PV-1 Installation Guide

3) To display the gauge pressure unit in Bar (0.01 bar resolution, 0 for atmosphere pressure, -1.00 bar for max vacuum),
For SYL-1813, enter the Basic Parameter setting mode with code 0089, a) Set input type, **Inty**, for 0-5 V input. b) Set the decimal point, **dot**= 00.00. c) Set the PuL= - 1.13. PuH = 0.13.

For SYL-2342Y, set dp =2, P-SL = -1.13. P-SH =0.13

4) To display the gauge pressure unit in kilopascal (0 for atmosphere pressure, -1000 kpa for max vacuum),
For SYL-1813, enter the Basic Parameter setting mode with code 0089, a) Set input type, **Inty**, for 0-5 V input. b) Set the decimal point, **dot**= 0000. c) Set the PuL=-1125, PuH = 125

For SYL-2342Y, set dp= 0, P-SL = -1125. P-SH =125

5) To display the gauge pressure unit in torr (760 torr for atmosphere pressure),
For SYL-1813, enter the Basic Parameter setting mode with code 0089, a) Set input type, **Inty**, for 0-5 V input. b) Set the decimal point, **dot**= 0000. c) Set the PuL= -095. PuH = 0855

For SYL-2342Y, set dp =0, P-SL = -95. P-SH =855

6) To display the gauge pressure unit in inch of water (0 for atmosphere pressure, -401 inch H2O for max vacuum),
For SYL-1813, enter the Basic Parameter setting mode with code 0089, a) Set input type, **Inty**, for 0-5 V input. b) Set the decimal point, **dot**= 0000. c) Set the PuL= -451, PuH = 50

For SYL-2342Y, set dp =0, P-SL = -451. P-SH =50

6) Set alarm

For SYL-1813 To set the alarm on at -4 psi and off at -5 psi, Enter code 0001 to set AH1 = -4.0 and AL1= - 5.0. The detail can be found in section C 2 of the instruction manual.

For SYL-2342Y, you can use ALM1, ALM2, HY-1 and HY-2 to set the alarm. Please see manual for details.

7) Zero Adjustment.

For SYL-1813, if the pressure does not show 0.00 bar or 0.0 psi when no pressure is applied, you can adjust the display to zero by shifting the value of PuL and PuH for the same amount. e. g. if the display shows 0.5 psi when no pressure is applied to the sensor, you can minus 0.5 from PuL and PuH. Set PuL to -16.8 (-16.3 - 0.5 = -16.8), and PuH 1.3 (1.8 - 0.5 = 1.3). Please note that the overall accuracy of the sensor is 1% of full scale. It is normal to see the zero point to fluctuate slightly.

For SYL-2342Y, if the pressure does not show zero at atmosphere pressure, you can use parameter Pb to adjust the zero. .e.g. If atmosphere pressure shows 2, set Pb=-2 will zero it.

B, Discussion

1) You can remove the negative sign by swap the setting of PuL with PuH, or P-SL with P-SH.

2) If the display is a positive value for maximum vacuum, COOL should be set to 0 to control the pump. If the display is a positive value for maximum vacuum, COOL should be set to 1 to control the pump.

3) If you want the display to display a different pressure unit than the ones listed, you need to find the value of PuL and PuH. Appendix 1 shows how the Auber PV-1 sensor parameter is determined. If you need help, please email us the specification of your sensor to info@auberins.com

4) The peak holding function is set for displaying the Maximum pressure only. To display the peak pressure from the last run, or display the pressure in the peak holding mode continuously, press the ">" key once. The MAX (MIN) LED will be on, indicating the display is in the peak mode. Press ">" again to change back to display the current pressure. Press and hold "Λ" for 3 second will reset the memory. Three additional peak parameters are turned off. They are, the time that the maximum pressure was recorded, the minimum pressure and its recording time. If you want see them, use code 0037 to turn on these functions. The detail can be found in section C3 of the instruction manual.

C. Appendix 1,

Example, Calculate the set up parameters for Auber PV2.5 sensor.

For a pressure sensor that is powered by 5 V DC, the linear range of the output signal will be higher than 0V and lower than 5 V due to the nature of mechanics and electronics. For this sensor -1 bar = 0.50V, 0 bar =4.5V. What these data tell us is that the sensor has a linear output between 0.5 and 4.5 V when the input signal is between -1 bar and 0 bar, In other words, within this range, the relationship between pressure and output voltage can be represented by

$$V = a \times P + b \quad (1)$$

Where P is the pressure, V is the voltage, **a** is the slop, and **b** is the intersection at zero pressure,

Because the meter is set for 0-5V linear input, we need to find out what is the pressure when we extend the equation (1) from 0.5-4.5V to the 0 ~5 V range. The pressure at 0 and 5 V output will be used to set the meter display scale.

Calculating slop **a** and intersection **b**

$$a = (4.5-0.5)/(0-(-1)) = 4$$

$$b = V - a \times P = 4.5$$

$$\text{So, } V = 4P + 4.5, \text{ or } P = (V - 4.5)/4$$

Therefore, at 0 V, P = -1.13 bar; at 5 V, P = 0.13 bar.

To display in pressure in PSI unit,

Set **dot** to **000.0**, **PuL** = **-16.3**, **PuH** = **1.8**

Please note, numbers used in the meter set up (page 1) may be slight different than this number. They were corrected by actual calibration with the meter for better accuracy.