

Instruction Manual

Distilling Controller, DSPR210

Version 1.1 (Feb 2016)



Caution

- This controller is intended to control equipment under normal operating conditions. Failure or malfunction of the controller may lead to abnormal operating conditions, which result in personal injury or damage to the equipment or other property. Devices (limit or safety controls) or systems (alarm or supervisory) intended to warn of or protect against failure or malfunction of the controller must be incorporated into and maintained as part of the control system.
- Installing the rubber gasket supplied will protect the controller front panel from dust and water splash (IP54 rating). Additional protection is needed for higher IP rating.
- This controller carries a 90-day warranty. This warranty is limited to the controller only.

1. Specifications

Input type	RTD (Resistance Temperature Detector): Pt100 Thermocouple (TC): K
Accuracy	± 0.2% Full scale
Temperature range	-328°F ~ +932°F, -200°C ~ +500°C
Response time	≤ 0.5s (when FILT =1)
Display resolution	1°C or °F for Mashing Mode. 0.1°C or °F for distilling Mode.
Control mode	Mashing, Distilling
Alarm function	Process high alarm
Power supply	85~260VAC/50~60Hz
Power consumption	≤ 5 Watt
Working Ambient temperature	0~50°C, 32~122°F
Dimension	48 x 48 x 86 mm (W x H x D, from the front panel to the back)
Mounting cutout	45 x 45 mm

2. Front Panel



Figure 1. The front panel of DSPR210

- 1). Top display.** This display will indicate the temperature sensor read out value. When timer is activated, it will show timer value and temperature alternatively.
- 2). Bottom display.** In distilling mode, this display will show the percentage of power been sent to the external SSR after the initial heat up phase. In mashing control mode, this display will show the set temperature.
- 3). Rotary switch (knob).** Turn it clockwise to increase the output power (or selected parameter value); turn it counter-clockwise to reduce the output power (or selected parameter value). Press it briefly to reset the timer (if enabled) and to switch between mashing and distilling mode. Press and hold it for 5 seconds to enter parameter settings menu.
- 4). Output indicator (OUT).** It shows how much power the regulator is sending out (as a 12VDC control signal pulse through terminal 9 and 10). When it is on solid, the output is 100% on. When it is off, there should be no output. When it is flashing, the frequency of the flashing is an indication of high or low power output. Higher frequency means higher power output.
- 5). Mashing mode indicator.** When indicator lit, the regulator is operating under mashing mode. When indicator is off, this regulator is operating under distilling mode.
- 6). Temperature setting adjusting indicator.** This is the small dot at the lower right corner. In mashing mode, when temperature set point is adjusted, it will start to flash. It reminds you that you need to press the knob to confirm the change. Otherwise, the temperature setting will return back in 2 seconds after you stop the adjustment.

3. Wiring Terminals

The pin assignment of the back terminals of DSPR210 is shown in Figure 2.

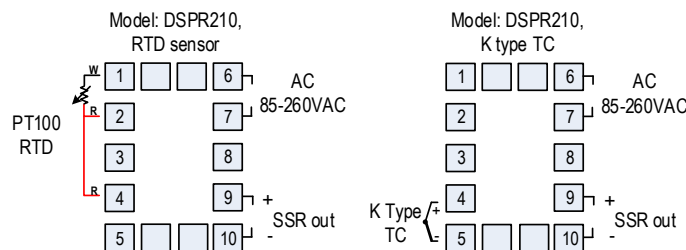

Figure 2. Terminals assignment of DSPR210.

3.1 Sensor connection

DSPR210 accepts two types of temperature sensor, Pt100 RTD sensor and K type thermocouple sensor.

3.1.1 RTD sensor

For a three-wire RTD with standard DIN color code, the two red wires should be connected to the terminals 2 and 4. The white wire should be connected to terminal 1. For a two-wire RTD, the wires should be connected to terminals 1 and 2. Jump a wire between terminals 2 and 4. Set controller input type, Sn to Pt.

3.1.2 Thermocouple

The thermocouple should be connected to terminals 4 and 5. Make sure that the polarity is correct. There are two commonly used color codes for the K type thermocouple. US color code uses yellow (positive) and red (negative). Imported DIN color code uses red (positive) and green/blue (negative). The temperature reading will decrease as temperature increases if the connection is reversed. Since the controller default setting was Pt100 RTD sensor, you need to change controller input type, Sn to "K" (See details in Section 6.1).

3.2 Power to the controller

The power cables should be connected to terminals 6 and 7. Polarity does not matter. It can be powered by 85-260V AC power source. Neither a transformer nor jumper is needed to wire it up. For the consistent with the wiring example described later, we suggest you connect the hot wire to terminal 6 and neutral to 7.

3.3 SSR output connection

The SSR control output of the DSPR210 provides a 12V DC signal that can control up to 5 SSRs in parallel. Connect terminal 9 to the positive pole of the SSR (terminal 3 for Auber's SSR). Connect terminal 10 to the negative pole of the SSR (terminal 4 for the Auber SSR). Please make sure the SSR is installed on the heat sink with proper current rating.

4. Display Status

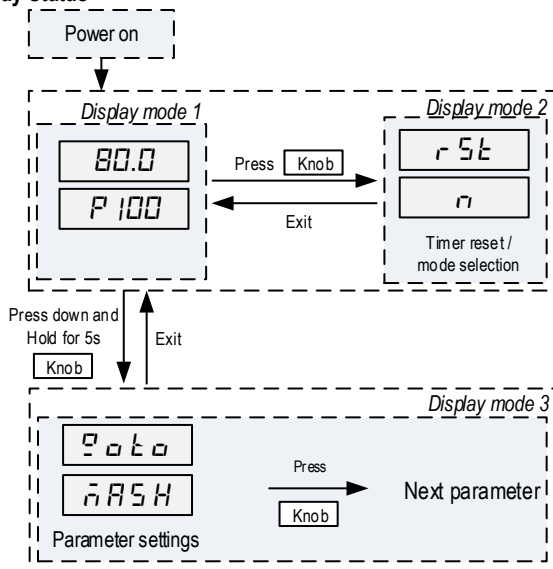

Figure 3. Display modes

Display mode 1 (Normal operating mode): When power is turned on, the top display window shows the current sensor temperature. When timer is activated, the top display will be switched between the current temperature and current time alternately. In mashing mode, the bottom display will show your set temperature. In distilling mode, the bottom display will show the current power output in percentage (e.g. P50 for 50% power output). Please check section 5 for how to adjust set temperature/power.

Display mode 2 (Time reset & Operation mode selection): This display mode allows you to reset the timer, or to switch between the mashing and distilling operation mode.

A short press of the knob will enter this display mode.

- 1) The display will show "rSt" on top and "n" at the bottom. This is the exit menu. If you enter this mode by accident, you can press the knob again to exit this display mode without changing anything.
- 2) Rotate the dial clockwise for one click will change the bottom display to "y". This menu is to reset the timer. Press the knob will reset the timer. It has two purposes. A) if you want to use the timer as regular timer without correlation to the temperature, you can start the timer at any time by the reset button. B) After timer is timed up and process ended, you can restart the process again by the reset button instead of power off the system and power it on again.
- 3) Rotate the knob with two clicks, the top display will change to "Mode" and bottom will show "Mash*". Rotate the knob again, the bottom display will change to "dStL". These two menus are for setting the controller to either mashing control

or distilling control mode. Press the knob will set the controller to the operation mode displayed. Please check section 5.1 for details.

Display mode 3 (Parameter settings): Press down and hold the knob for 5 seconds to enter the display mode 3. Please check section 6 for details.

5. Operation

5.1 Operation mode selection

This controller offers two operation modes, mashing and distilling. When the mashing mode is selected, the controller functions as a temperature controller. It automatically adjusts the power output to hold the temperature at set point. When distilling control mode is selected, the controller functions as a power regulator. It allows the user to manually adjusting the power to control the strength of the boil. The temperature resolution for mashing mode is 1 degree; for distilling mode is 0.1 degree. Figure 4 shows how to select and switch between these two modes.

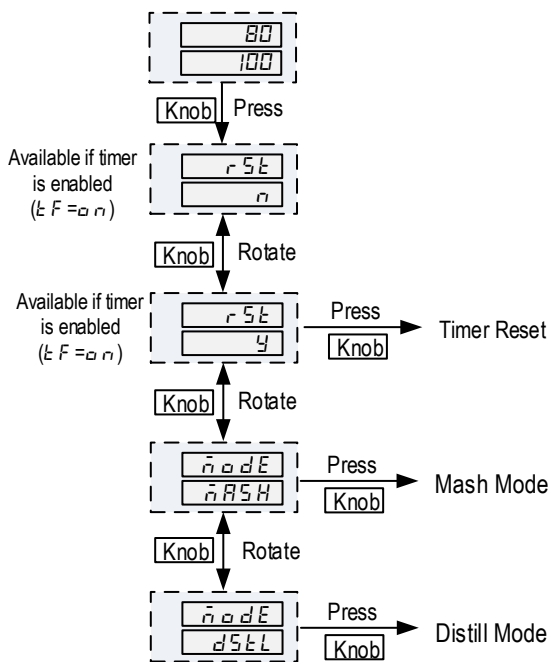

Figure 4. Flow chart for time reset & operation mode selection

Press the knob once. The display will show "rSt". Rotate the knob with two clicks, the top display will change to "Mode" and bottom will show "Mash*". Press the knob will set the controller to mashing mode. When mashing mode is selected, the yellow indicator on the top left corner of the panel will lit. This indicator will be off if the distilling mode is selected.

*: due to the limitation of 7 segment LED display, the letter "M" is displayed as "n".

5.2 Mashing Operation

When first powered up, make sure the controller is in the mashing mode: The yellow colored mashing mode indicator on the upper left corner should be on, and the bottom display has no "P" on the left. If not, please change the control mode to mashing mode as discussed in section 5.1 above. If you were using the controller in the mashing mode when powered off last time, the controller will start in mashing mode.

After controller is powered up, the top LED displays the current temperature reading from the sensor. If temperature sensor is not connected, it will show EEEE. The bottom LED displays your set temperature. To adjust its value, just rotate the knob. Once the value of the setting is changed, a small dot on the right bottom corner will be flashing. It tells you that the setting has been changed but not confirmed. After you adjust the temperature to the desired number, **push the knob to confirm the change**. After confirmation, the new setting will remain on the display and the dot will be turned off. If you forgot to push the dial, the display

will return to original set temperature after 2 seconds. The set point will remain unchanged. This mechanism is for preventing temperature set point change by accident.

The Output indicator will stay on solid right after powered up. This mean the controller is heating up the kettle at maximum speed. Once the temperature is getting close to the set point, the output indicator will start to flash at slower rate or take a pause. It indicates the controller is trying to modulating the power to hold the temperature stable.

For how to set up the timer in mashing mode, please read section 6.2.

5.3 Distilling Operation

When first powered up, make sure the controller is in the distilling mode: the mashing mode indicator on the upper left corner is off and bottom display has a "P" on the left. If not, change the control mode to distilling mode as discussed in section 5.1 above. If you were using the controller in the distilling mode when powered off last time, the controller will start in distilling mode.

The top LED displays the current temperature reading from the sensor. If temperature sensor is not connected, it will show EEEE. The controller will not turn on the heater if the sensor is not connected. The bottom LED displays the distilling output in percentage of the power. For example, if you use a 5500 Watts heater, "P50" mean the heater is running at 50% of power, or 2750 Watts (5500x50%=2750). The symbol "P" on the left is for making sure that the display does not get confused with temperature setting of the mashing mode. You can rotate the knob to adjust the output value. The new setting will take effect automatically. There is no need to push the knob to confirm as the temperature setting change in the mashing mode. For the first time use, while the controller is still in the acceleration phase, you should set the distilling output to a value below 60%. Once the controller finished the acceleration, it will switch to this power level automatically. After getting familiar with your system, you can set to a higher value.

When the controller is powered up, the output indicator will stay on solid. This mean the controller is in the acceleration phase. Once the temperature rise above the acceleration phase, the power output will be reduced to the value as shown on the bottom display. The Output indicator will start to flash at slower rate.

Note, when adjusting the distilling output setting while the controller is still in the acceleration phase, the new setting will be shown on the bottom display. However, it will not take effect until the acceleration phase is finished. If you want to manually control the power output during the entire distilling process, set **dAST** to zero (see section 6.3 for details).

For how to set up the distilling mode, please read section 6.3.

6. Control Parameters

The parameters are divided into three groups (figure 5): **mash** for mashing control, **dStL** for distilling control, and **syst** for system configuration. Some function may have different value when used in different mode. To differentiate them, we use slight different symbol. For example, "t" is used for the time setting in the mashing mode. "dt" is used for the time setting in the distilling mode. To enter parameter setting mode, press and hold the knob for at least 5s. Then you will see "Goto" on the top display. Rotate the knob, you will see the bottom display changes with three different names: Mash (for mashing parameters, figure 7), dStL (for distilling parameters, figure 8) and Syst (for system settings, figure 6). The parameter values are stored in the controller memory. All the settings remain unchanged if you power it off.

Push the dial to enter your selected group. Then top display shows the current selected parameter name, and the bottom display shows its value/options. Rotate the knob clockwise to increase the value, and rotate it counter-clockwise to reduce the value. Faster rotating speed will change the value rapidly. Once finished, press knob again to confirm and go to next parameter. You can keep pressing down the knob repeatedly to exit the setting quickly.

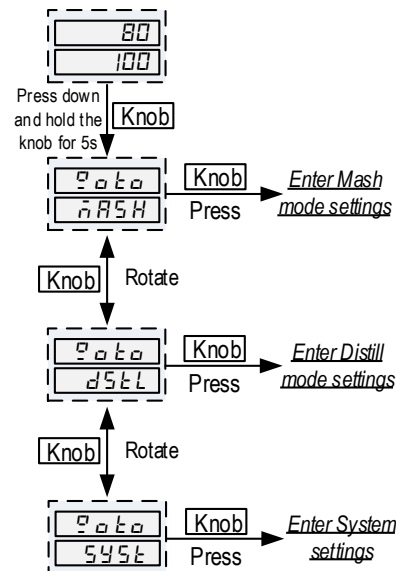

Figure 5. Parameter group selection

6.1 System settings

Parameters that are shared by both control modes are under this group.

Table 1. System configuration

System Configuration					
Display	Code	Description	Setting Range	Initial Setting	Remark
tF	tF	Timer function	ON, OFF	ON	Note 1
FF	FF	Hi Temperature finishing function	ON, OFF	ON	Note 6
tdlr	tdlr	Timer counting direction	dn, uP	dn	Note 1
Pb	Pb	Temperature reading offset	-100~+100 °C or °F	0	Note 2
Sn	Sn	Input sensor type	Pt, K	Pt	Note 3
FILt	Filt	Digital filter	1-6	1	Note 4
C-F	C-F	Temp. display unit	°C, °F	°F	Note 5

Note 1: Timer settings: tF, tdlr

tF: The **timer function** is controlled by a master parameter tF. When it is set to **ON**, the timer function (for both mashing and distilling modes) is enabled. When tF is set to **OFF**, the timer function is disabled.

tdlr: Timer direction parameter. Set it to **up** for timer counting up and **dn** for timer counting down.

Note 2: Input offset: Pb

Pb is used to set an input offset to compensate the error produced by the sensor or input signal itself. For example, if the controller displays 2°C when probe is in ice/water mixture, setting Pb = -2, will make the controller display 0°C.

Note 3: Input sensor type: Sn

Sn is the sensor input selection for this controller. Two available options:
Pt: PT100 RTD sensor
K: K type thermocouple

Note 4: Digital sensor filter

If measurement input fluctuates due to noise, then a digital filter can be used to smooth the input. "FILt" may be configured in the range of 1 to 6. Stronger filtering increases the stability of the readout display, but causes more delay in the response to change in temperature. By default, FILt is set to 1 (weakest filtering).

Note 5: Temperature unit setting: C-F

You can set the regulator's display to either Celsius or Fahrenheit.

C: Celsius display

F: Fahrenheit display

Note 6: High temperature turn off function: FF

This regulator has an automatic shut off feature, when the actual temperature is over the limit temperature you set. The automatic output power shut off mechanism is latched just like a limit controller. Once it is shut off, the heater will not turn on unless the system is reset. Please check section 6.3 for details.

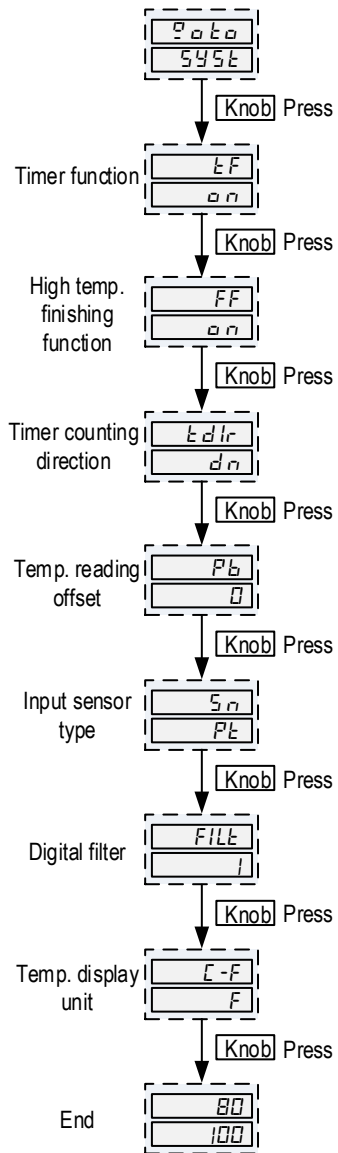

Figure 6. Flow chart for system parameters

6.2 Mashing Mode

Table 2. Mashing parameters

Mashing Mode Parameters					
Display	Code	Description	Setting Range	Initial Setting	Remark
t	t	Mashing time set value	00:00-99:99 (hour: minute)	1:00	Note 7
tSP	tSP	Mashing timer start temp.	-999~+9999 °C or °F	151	
ALH	ALH	Mashing alarm set temp.	-999~+9999 °C or °F	150	Note 8
EO	EO	Mashing ending options	ON, OFF	OFF	Note 7
oScr	oScr	Overshoot correction	-100~+100	0	Note 9
AttE	AttE	Attenuation constant	-2~+2	0	

Note 7: Timer Function: t, tSP, EO

This timer function allows the controller to showing the mash time. It makes a beeping sound when timed out and will display the process is ended. It can also automatically shut off the controller's power output after time out. The **time duration** is set by the **t** parameter for mashing mode. The unit is hour: minutes.

When timer function is enabled, the timer counting will be started by **timer start temperature, tSP**. When temperature reaches timer start temperature, the timer starts to count. After timer started counting, it will continue even if the temperature drops below this start temperature. The timer can be reset to start from beginning again. To reset the timer, press the knob momentarily, the display will show **rSt** on top and "n" at the bottom, rotate the dial clockwise will change the bottom display to "y". Press the knob again will reset the timer (Figure 4) After the timer starts, the top display will be switched between the current temperature and current time alternately in every 6 seconds. The temperature and time display can be easily differentiated with their appearance. The temperature reading has two or three digits. For example, 212 degrees will be displayed as "212". The timer display has four digits with flashing colon in the middle. For example, "01:20" for 1 hour 20 minutes.

When time counting ends, the controller will generate six long beeps. The top display will switch between the current temperature and "End" alternately. After timer ends, the power output can be configured either to continue heating, or shut off. It is controlled by the parameter called **ending options, EO**. Set it to **ON** for continue heating, set it to **OFF** to turn off the output.

If you want to use the timer as a regular timer without correlating to the temperature setting, you can set the tSP below the ambient temperature (or zero). The timer will start as soon as the regulator is powered up. You can use the reset button (rSt) to reset the timer at any time.

Note 8: Alarm Function: ALH

DSPR210 has a built-in buzzer that can be programmed to beep when temperature reaches the **alarm set temperature, ALH**. The alarm will generate four short beeps every time the temperature rise from below ALH to higher than ALH. The alarm function can be used to notify the operator when temperature is approach the boil. The alarm function does not affect the heating or the time function, it only provides the alarm sound.

Note 9: Temperature Control Tuning Parameters: oScr, AttE

The mashing control mode utilizes AI algorithm instead of the commonly used PID or On/off control algorithm. The program is optimized for beer mashing. For most system, there is no need to tune. It allows the system to heat up at maximum speed, then hold the temperature stable with one-degree precision. If you are not satisfied with the control result, these two parameters will help you to fine tune the system. The **overshot correction, oScr** is for adjusting the temperature overshoot during the initial heat up. For example, if the temperature overshoot 3 degrees, set oScr = 3 should remove the overshoot. This parameter has no effect after the temperature reach the set point. The **attenuation constant, AttE** is for adjusting the temperature stability during mashing. The value is from -2 to +2. The default value is 0. If the temperature fluctuates more than one degree, user can increase the value. If the controller takes too much

time to correct the temperature drop, user can reduce the AttE to make the system more responsive.

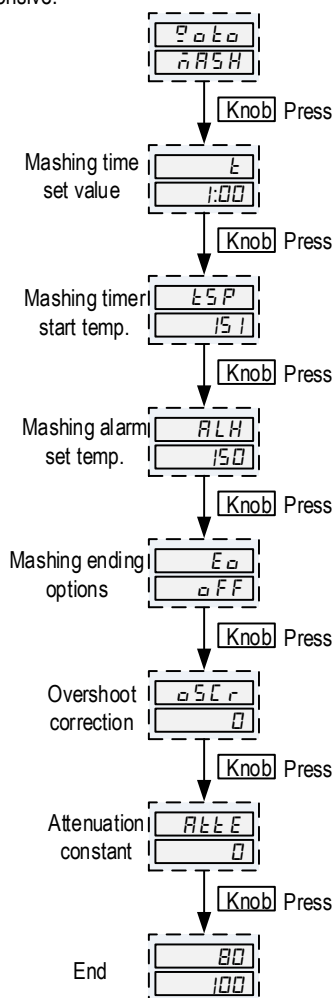

Figure 7. Flow chart for mashing mode settings

6.3 Distilling mode

For the easy of discussion, we divide the distilling mode into two phases, the **initial heating phase** and **distilling phase**. During the initial heating phase, power output is set high to accelerate the temperature rise. During the distilling phase, the power output is lowered to prevent the impurity being evaporated. We name the output setting for the distilling phase as “**Distill Output**” setting. Its value is always displayed on the bottom LED display and can be adjusted by turning the knob.

Table 3. Distilling parameters

Distilling Mode Parameters					
Display	Code	Description	Setting Range	Initial Setting	Remark
dAST	dAST	Distilling acceleration set temp.	-999~+9999 °C or °F	170	Note 10
dOUT	dOUT	Distilling acceleration output power	0~100%	100	
dt	dt	Distilling time set value	00:00~99:99 (hour: minute)	6:00	Note 11
dtSP	dtSP	Distilling timer start temp.	-999~+9999 °C or °F	172	
dALH	dALH	Distilling alarm set temp.	-999~+9999 °C or °F	170	Note 12
dFSP	dFSP	Distill finishing temperature	-999~+9999 °C or °F	200	Note 13
dEO	dEO	Distilling ending options	ON, OFF	OFF	Note 14

Note 10: Acceleration heating function: dAST, dOUT

DSPR210 can accelerate heating speed of the initial heating phase by running the heater at high power, then reduce the power once the temperature is getting close to the boil. The heating acceleration is controlled by two parameters, **Distilling acceleration set temperature, dAST** and **Distilling acceleration output power, dOUT**. The dAST set the temperature limit that below this temperature, the controller will output at a power determined by the dOUT. When temperature rise to the dAST, the output will automatically reduce to the evaporation of impurity. Since the heater power and liquid volume varies between each application, we suggest the dAST to be set at least 10 degree (Fahrenheit) below the boiling point for the first time use. As you getting familiar with your system, you can change this setting to higher or lower. The dOUT is the power used during initial heating phase. The unit is in percent of power. It should be set to 100% unless you have a very powerful heater with very small amount of liquid. The dOUT setting does not limit the power regulation range for distilling phase. **If you don't need to use this feature, set dAST to 0, so this controller will work as a manual mode controller over the entire temperature range.**

Note 11: Timer Function: dt, dtSP.

This timer function allows the controller to showing the distilling time. It makes a beeping sound when timed out and will display the process is ended. It can also automatically shut off the controller's power output after time out. The **time duration** is set by dt parameter for distilling mode. The unit is hour: minutes.

When timer function is enabled, the timer counting will be started by **timer start temperature, dtSP**. When temperature reaches timer start temperature, the timer starts to count. After timer started counting, it will continue even if the temperature drops below this start temperature. The timer can be reset to start from beginning again. To reset the timer, press the knob momentarily, the display will show **rSt** on top and “n” at the bottom, rotate the dial clockwise will change the bottom display to “y”. Press the dial again will reset the timer (Figure 4)

After the timer starts, the top display will be switched between the current temperature and current time alternately in every 6 seconds. The temperature and time display can be easily differentiated with their appearance. The temperature reading has two or three digits. For example, 212 degrees will be displayed as “212”. The timer display has four digits with flashing colon in the middle. For example, “01:20” for 1 hour 20 minutes.

Note 12: Alarm function for removing the foreshot/heads: dALH

DSPR210 has a built-in buzzer that can be programmed to beep when temperature reaches the alarm set temperature, AH. The alarm will generate four short beeps every time the temperature rise from below AH to higher than AH. The alarm function can be used to notify the operator to remove the foreshots/heads at specific temperature close to the component boiling point. The alarm function does not affect the heating or the time function, it only provides the alarm sound.

Note 13: High temperature finish function, FF and dFSP.

This regulator can stop the distilling when the actual temperature is over the limit temperature you set. The function is latched just like a limit controller. Once it is the process is ended, it will not start again when temperature drops back, unless the system is reset.

This feature is controlled by two parameters: **High temperature finish function, FF** and **finishing temperature set value, dFSP**. (FF is in system configuration menu, please check section 6.1.) If FF is set to ON, this feature is enabled. The dFSP set the finish temperature limit. When the reading temperature is below dFSP temperature, the controller will work as normal. When the temperature rise over the dFSP, the process will be automatically stopped until you reset the system (please refer figure 4 to reset).

Note 14, Distilling Ending Option: dEO.

When the timer counting ends, or when the distill finishing temperature is reached, the controller will generate six long beeps. The top display will switch between the current temperature and “End” alternately. After the process ends,

the power output can be configured either to continue heating, or shut off. This is controlled **ending options, dEO**. Set it to **ON** for continue heating, set it to **OFF** to turn off the output.

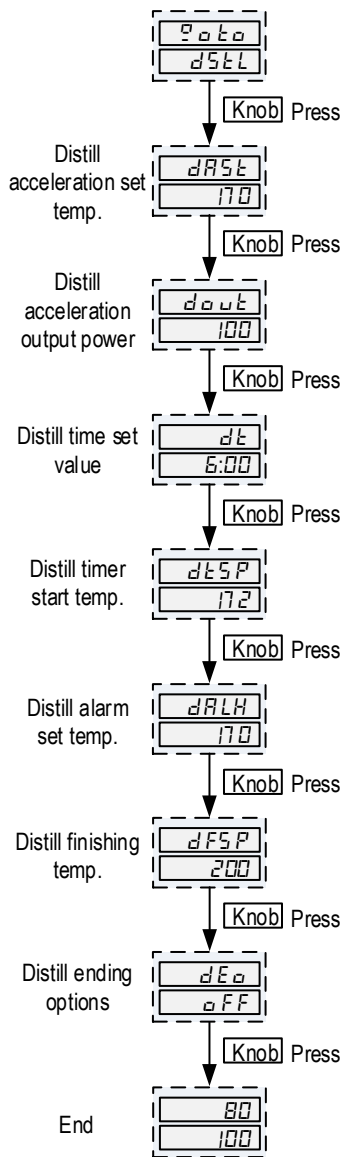

Figure 8. Flow chart for distilling mode settings

If you want to use the timer as a regular timer without correlating to the temperature setting, you can set dFSP below the ambient temperature (or just zero). The timer will start as soon as the regulator is powered up. You can use the reset button (rSt) to reset the timer at any time.

7. Application examples:

1. Example for alcohol distilling

Set the high power accelerated heating limit to 170.0°F (76.7°C) and power output to be at 100% of the element capacity, set distilling power at 30%. Set the foreshots/heads alarm at 172°F. Set the distillation ending criterial to be either when temperature rise to 200.0 °F or when the time is more than 3 hours. When the controller is powered up, it will heat the wash with full power. After the wash temperature reaches 170°F, the power is automatically reduced to 30%. When temperature reaches 172°F, the alarm will beep four times to notify the operator that temperature is close to the alcohol boil temperature so that he can remove the heads. Soon the temperature rise to 173.0°F, the timer is activated. After distilling for a while the content of alcohol is depleted and temperature starts to rise. Once the temperature reaches 200.0°F, the heater is turned off and the

controller will send long beeps and flashing "End" on the display, if the temperature does not rise to 200.0°F after 3 hours, the heater will also be turned off. During the distillation, the user can use the rotary knob to fine tune the boil at any time. The figure below shows how the power is correlated to the temperature and time.

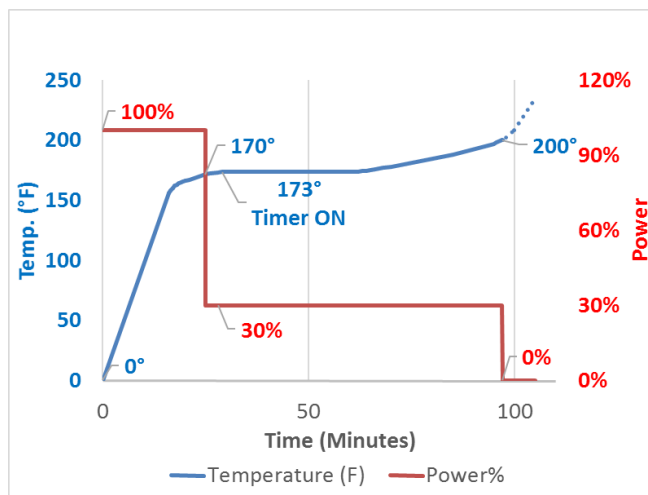

Figure 6. Example for alcohol distilling (Power output correction with temperature and time.) Setting: dAST=170, dOUT=100, dt=3:00, dFSP=200.0, dALH=172.0 dtSP=173, tF=ON, FF=ON, dEO=OFF. Dial=P30.

2. Timer operation example:

The timer can be used for several ways to help the distilling process.

1) Use it to automatically control the distilling time (distilling mode).

Set the parameter as following
tF=on, dtSP=210, tdlr=dn, dEO=OFF, dt=1:30,
The timer will start to count when temperature reaches 210 degrees. The timer will count down from 1:30, when time out, the controller will stop heating, beeps, and flash "End".

2) Use the timer as a regular timer (distilling mode).

Set dtSP below the ambient temperature so that timer is available, set dt to a very long time so that it will not end before operator decide to end the distill. The counting direction should be up. Use the reset button (rSt) to reset the timer at any time
tF=on, dtSP=50, tdlr=up, dEO=on, dt=60:00.

3) Use the timer as a regular timer (mashing mode).

Set tSP below the ambient temperature so that timer is available, set t to a very long time so that it will not end before operator decide to end the mash. The counting direction should be up. Use the reset button (rSt) to reset the timer at any time
tF=on, tSP=50, tdlr=up, EO=on, t=60:00.

3. Use it as a manual regulator (similar to DSPR1)

To use it as manual regulator with temperature reading, please set it to distilling mode. Disable timer and high temperature turn off function. Set distilling acceleration set temperature below ambient temperature (or just zero). Then you can rotate the knob to adjust the power.
Mode=distilling, tF=off, FF=off, dAST=0

8. Wiring Examples

Example 1. Here are two wiring diagrams of how to connect a DC triggered AC SSR with this power regulator.

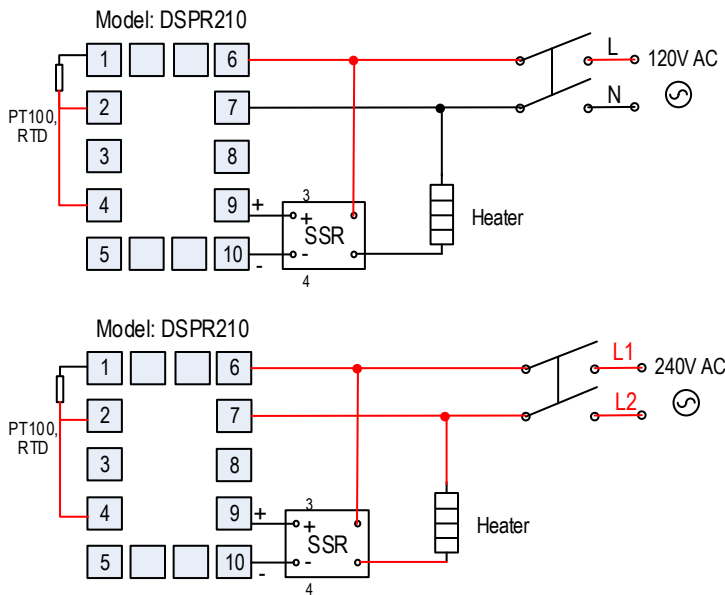

Figure 9. Wiring examples of controlling a heater with SSR and DSPR210 in a 120VAC system (upper) and in a 240VAC system (lower).

9. Common sensor errors:

This regulator will display error message or incorrect temperature reading if your sensor input type (Sn) is set incorrectly, or your sensor is not connected. Please check the table below:

Table 4. Sensor error table

Sn set value	Sensor connection	Error condition
Sn = pt	K type thermocouple is connected	Condition 1
Sn = pt	No sensor is connected	Condition 1
Sn = k	No sensor is connected	Condition 1
Sn = k	PT100 RTD is connected	Condition 2

Condition 1:

Top display will flash "orAL" and "932" alternatively, if you set it to Fahrenheit display (C-F = °F); or "orAL" and "500" alternatively, if you set it to Celsius display (C-F = °C).

Condition 2:

Top display will show a large number, which is close to 932, if you set it to Fahrenheit display (C-F = °F); or close to 500, if you set it to Celsius display (C-F = °C). The top display will not flash "orAL" under this condition.

Auber Instruments

5755 North Point Parkway, Suite 99

Alpharetta, GA 30022

www.auberins.com

Email: info@auberins.com Tel: 770-569-8420

Copyright 2007-2016, Auber Instruments All Rights Reserved.

No part of this manual shall be copied, reproduced, or transmitted in any way without the prior, written consent of Auber Instruments. Auber Instruments retains the exclusive rights to all information included in this document.