

Instruction Manual

EZboil for Step Mashing and Boiling Process Automation, DSPR310D

Version 1.1 (Aug, 2018)



Caution

- This controller is intended to control equipment under normal operating conditions. Failure or malfunction of the controller may lead to abnormal operating conditions, which result in personal injury or damage to the equipment or other property. Devices (limit or safety controls) or systems (alarm or supervisory) intended to warn of or protect against failure or malfunction of the controller must be incorporated into and maintained as part of the control system.
- Installing the rubber gasket supplied will protect the controller front panel from dust and water splash (IP54 rating). Additional protection is needed for higher IP rating.
- This controller carries a 90-day warranty. This warranty is limited to the controller only.

1. Specifications

Input type	RTD (Resistance Temperature Detector): Pt100
Accuracy	± 0.2% full scale
Temperature range	-328°F ~ +932°F, -200°C ~ +500°C
Response time	≤ 0.5s
Display resolution	1°C or °F
Control mode	Step Mashing, Boiling
Program step	Up to 8 program steps for mashing mode Up to 9 timer events for boiling mode
Timer range	Up to 99h for each step/event
Relay output	Relay contact: 3A for resistive load. 1A for inductive load
Power supply	85~260 VAC/50~60 Hz
Power consumption	≤ 5 Watt
Working Ambient temperature	0~50°C, 32~122°F
Dimension	48 x 48 x 100 mm (W x H x D, from the front panel to the back)
Mounting cutout	45 x 45 mm

2. Front Panel



Figure 1. The front panel of DSPR310D.

- 1. Top display.** This display indicates the temperature sensor readout value. It may also show time and temperature alternately. (see section 4)
- 2. Bottom display.** In boiling mode, this display will show the percentage of power being sent to the external SSR after the initial heat up phase. In mashing mode, this display will show the set temperature. It may also flash step number alternately under these two modes. (see section 4)
- 3. Temperature setting adjusting indicator.** This is the small dot at the lower right corner. In mashing mode, when temperature set point is adjusted, it will start to flash. It reminds you that you need to press the knob to confirm the change. Otherwise, the temperature setting will return back in 2 seconds after you stop the adjustment.
- 4. AL1 indicator.** This red LED indicates the status of Relay 1 (AL1). When it is on, relay 1 is closed; when it is off, relay 1 is open.
- 5. AL2 indicator.** This red LED indicates the status of Relay 2 (AL2). When it is on, relay 2 is closed; when it is off, relay 2 is open.
- 6. Mashing mode indicator (MASH).** This yellow LED light indicates the operation mode of the controller. When it is on, controller is in mashing mode; when it is off, controller is in boiling mode.
- 7. Output indicator (OUT).** This green LED light is SSR output indicator. It shows how much power the regulator is sending out (as a 12VDC control signal pulse through terminal 6 and 7). When it is solid ON, the output is 100% on. When it is off, there is no output. When it is flashing, the frequency of the flashing is an indication of high or low power output. Higher frequency means higher power output percentage.
- 8. Rotary switch (knob).** Turn it clockwise to increase the output power (or selected parameter value); turn it counter-clockwise to reduce the output power (or selected parameter value). Press it momentarily to reset the timer (if enabled) and to switch between mashing and boiling mode. Press and hold it for 5 seconds to enter parameter settings menu. (see section 6)
- 9. Program Function Key A & B.** There are two function keys named "A" (or "RUN") and "B" (or "HOLD/STOP"). Key A can be used to start or resume the program (step mashing mode) or power output/timer (boiling mode). Key B can be used to hold or stop the program or timer. Please see section 5.2.2 and 5.3.3. Key A can also be used to mute the built-in buzzer in specific situations. Please refer to section 5.3.3 for more details.

3. Wiring Terminals

The pin assignment of the back terminals of DSPR310D is shown in Figure 2.

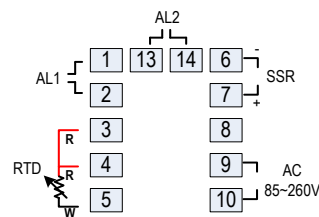

Figure 2. Terminal assignments of DSPR310D.

3.1 Sensor connection

DSPR310D only accepts Pt100 RTD temperature sensor. For a three-wire RTD with standard DIN color code, the two red wires should be connected to the terminals 3 and 4. The white wire should be connected to terminal 5. For a two-wire RTD, the wires should be connected to terminals 4 and 5. Jump a wire between terminals 3 and 4.

3.2 Power to the controller

The power cables should be connected to terminals 9 and 10. Polarity does not matter. It can be powered by 85-260 VAC power source. Neither a transformer nor jumper is needed to wire it up. For the consistent with the wiring example

described later, we suggest you connect the hot wire to terminal 10 and neutral to 9.

3.3 SSR output connection

The SSR control output of the DSPR310D provides a 12 VDC signal that can control up to 5 SSRs in parallel. Connect terminal 7 to the positive pole of the SSR (terminal 3 on Auber's SSRs). Connect terminal 6 to the negative pole of the SSR (terminal 4 on Auber's SSRs). Please make sure the SSR is installed on the heat sink with proper current rating.

4. Display Status

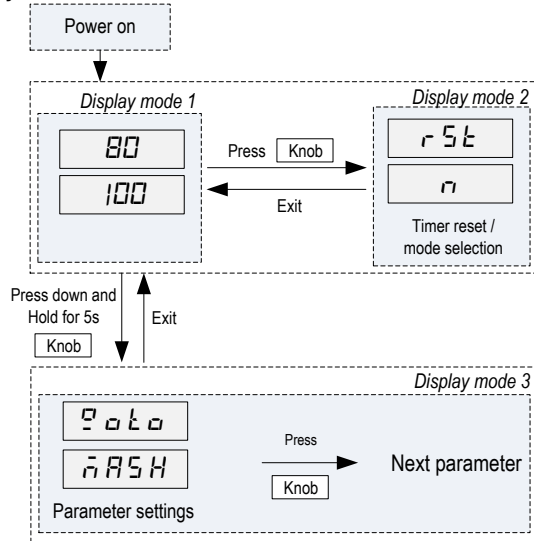

Figure 3. Display modes of DSPR310D.

Display mode 1 (Normal operating mode): 1) When MASH indicator is ON, the controller is in **step mashing mode**. The top display will show reading temperature, and it may also flash the remaining time for the current step alternately (see section 5.2.1). The bottom display will flash set temperature in this step and current step number (e.g. P-1 for step 1) alternately. 2) When **MASH indicator is OFF**, the controller is in **boiling mode**. The top display will show reading temperature, and it may also flash the total remaining time of timer events alternately (see section 5.3.1). The bottom display will flash current output power percentage (e.g. P50 for 50% power output) and current step number alternately.

Display mode 2 (Step program reset & Operation mode selection): This display mode allows you to reset the timer (mashing and boiling modes), or to switch between the mashing and boiling operation mode.

A short press of the knob will enter this display mode.

1) The display will show "rSt" on top and "n" at the bottom. This is the exit menu. If you enter this mode by accident, you can press the knob again to exit this display mode without changing anything.

2) Rotate the dial clockwise for one click will change the bottom display to "y". This option is to stop the program steps/timer events. Bottom display will flash "stop". It functions the same if you press and hold the Key B for 5 seconds.

3) Rotate the knob with two clicks, the top display will change to "Mode" and bottom will show "Mash", which is for step mash mode. Rotate the knob again, the bottom display will change to "Boil", which is for boil mode. These two menus are for setting the controller to either step mashing control or boiling control mode. Press the knob will set the controller to the operation mode displayed. Please check section 5.1 for details.

Display mode 3 (Parameter settings): Press down and hold the knob for 5 seconds to enter the display mode 3. Please check section 6 for details.

5. Operation

5.1 Operation mode selection

This controller offers two operation modes, step mashing and boiling. When the step mashing mode is selected, the controller functions as a temperature controller with steps. It automatically adjusts the power output to hold the temperature at set point in that step. When boiling control mode is selected, the controller functions as a power regulator. It allows the user to manually adjusting the power to control the strength of the boil. Figure 4 shows how to select and switch between these two modes.

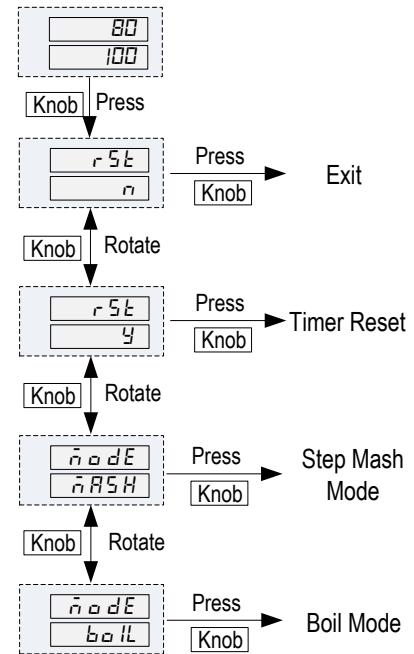
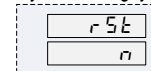

Figure 4. Flow chart for timer reset & operation mode selection.

Press the knob once. The display will show "rSt". Rotate the knob with two clicks, the top display will change to "Mode" and bottom will show "Mash". Press the knob will set the controller to mashing mode. When mashing mode is selected, the yellow indicator on the top left corner of the panel will lit. This indicator will be off if the boiling mode is selected.

Note 1: due to the limitation of 7 segment LED display, the letter "M" is displayed as "n".

Note 2: if you mistakenly enter this layer of setting, you need to dial the knob to show:



Then press the knob again to exit. Nothing will be changed.

5.2 Step Mashing Operation

5.2.1 Introduction

When first powered up, make sure the controller is in the mashing mode: The yellow colored mashing mode indicator on the upper left corner should be on, and the bottom display has no "P" on the left. If not, please change the control mode to mashing mode as discussed in section 5.1 above. If you were using the controller in the step mashing mode when powered off last time, the controller will start in the step mashing mode.

After controller is powered up, the top LED displays the current temperature reading from the sensor. If temperature sensor is not connected, it will show "orAL". When the step mashing timer is triggered and counting down, the top display will start to display the current temperature and the remaining time for the current step alternately. The bottom LED displays your current set temperature, and it may also flash current step status alternately, including "run", "hold" and "stop".

The Output indicator will stay on solid right after powered up. This mean the controller is heating up the kettle at maximum speed. Once the temperature is getting close to the set point, the output indicator will start to flash at slower rate or take a pause. It indicates the controller is trying to modulating the power to hold the temperature stable.

5.2.2 Step program settings and key functions:

Press and hold the knob to enter the step program setting mode. Select "ProG" and press set to enter the menu. The parameter is listed in the sequence of C1, t1, C2, t2... until t6. C1, C2...C6 is the temperature set point for each step. t1, t2 ... t6 is the time duration for each step (See section 6.2). The time unit is in hh:mm. You can also set time to "hold", or "stop" by keep turning the knob counterclockwise, until the display reading is below the zero.

If you set time to hold, the controller will hold the temperature at the set temperature at the corresponding step. Once the program is on hold, you need to manually resume the program by pressing the Key A momentarily. Please note that the hold function will need a step to accomplish. In other word, if you program one step for hold in the process, the total number of programmable temperature steps will be reduced from 6 to 5.

Difference between "HOLD" and "STOP":

"HOLD" will maintain your target at previous set temperature in mashing mode, and pause your timer counting in boiling mode (if timer is enabled). For example, assuming the set temperature is 150F before "HOLD" action, after "HOLD", the controller will maintain at 150F as well. After you pause your timer in boiling mode, you can also adjust the power output percentage. To resume, you can press Key A momentarily.

"STOP" will stop the whole program and disable the output. There will be no output then, no matter what status is before "STOP" action. To resume, you can press Key A momentarily to resume the program/timer.

Difference between "END" and "STOP":

There are two ways to program the finish of the mashing process: "STOP" and "END". You can "STOP" the program at your set step, and heating is stopped at same step; you can "END" the program when controller has finished all steps, and you can set the controller stop heating (like "STOP"), or continue heating, once the program is "end".

To "STOP" the program, you need to set the time duration of target step as "STOP", and you don't need to change other unused steps. Once "STOP", you can only restart the program from the first step (press Key A), and you cannot go to the next step after that "STOP" step. To "END" the program, you need to set all the time duration of unused steps to zero. The controller will skip these unused steps and "END" the program directly. When program is ended, user can set the controller stop heating or continue heating (parameter EO in step mashing mode, bEO in boiling mode). If you want to run another step mashing program, you need to 1) simply reboot the controller, or 2) change "END" status to "STOP" status by the knob at first, then push Key A to restart: Push down the knob momentarily and change "rst" to "y", then push down the knob again to confirm.

Key A and B are used under step mashing mode. Key A can be used to start the program, or resume the held program. Key B can be used to hold or stop the program manually. Press Key B momentarily, the program will be on hold; Press and hold Key B for 5 seconds, bottom display will flash "STOP", and the program will stop.

Tip: You can even hold the timer (by pressing key B momentarily) before the timer of first step is started (when the temp. difference between reading and set temp. is larger than tsp value, note 3 in page 5). Then when temp. difference is less than tsp value, timer will be started and held at same time. You will hear the beeping notification. This tip can create one "HOLD" step before step 1 in mashing mode.

5.2.3 Relay settings

User can program the build-in relays to be synchronized with mashing temperature steps. User can selectively turn on (or off) the relay(s) at specific steps. These relays can also be programmed to be synchronized with the internal beeper so that external buzzer can be used for notification at the beginning and end of each step. (see section 6.4.2, note 12)

5.2.4 Adjusting parameter value

Two ways to adjust set temperature:

1). To adjust the set temperature in current step temporarily (it will not affect the pre-saved parameter values in PROG menu), you can just rotate the knob. Once the value of the setting is changed, a small dot on the right bottom corner will be flashing. It tells you that this setting has been changed but not confirmed yet. After you adjust the temperature to the desired number, **press down the knob to confirm this change**. After confirmation, the dot will be turned off. If you forgot to press down the knob, the display will return back to original set temperature after 2 seconds. The set point will remain unchanged. This mechanism is for preventing temperature set point change by accident.

2). To adjust the set temperature permanently, you need to enter "PROG" menu and adjust settings there accordingly. (see section 6.2)

5.3 Boiling Operation

5.3.1 Introduction

When first powered up, make sure the controller is in the boiling mode: the mashing mode indicator on the upper left corner is off and bottom display has a "P" on the left. If not, change the control mode to boiling mode as discussed in section 5.1 above. If you were using the controller in the boiling mode when powered off last time, the controller will start in in boiling mode.

The top LED displays the current temperature reading from the sensor. If temperature sensor is not connected, it will show "orAL". The controller will not turn on the heater if the sensor is not connected. If timer is running, the top display will flash current reading temperature and the total remaining time of timer events alternately. The bottom LED displays the current boiling output in percentage of the power, and it may also flash current step status alternately, including "run", "hold" and "stop". For example, if you use a 5500 Watts heater, "P50" mean the heater is running at 50% of power, or 2750 Watts (5500 x 50% = 2750). The symbol "P" on the left is for making sure that the display does not get confused with temperature setting of the mashing mode. You can rotate the knob to adjust the output value. The new setting will take effect automatically. There is no need to push the knob to confirm as the temperature setting change in the mashing mode. For the first time use, while the controller is still in the acceleration phase, you should set the boiling output to a value below 60%. Once the controller finished the acceleration, it will switch to this power level automatically. After getting familiar with your system, you can set to a higher value that produce a rolling boil without boiling over.

Note, when adjusting the boiling output setting while the controller is still in the acceleration phase, the new setting will be shown on the bottom display. However, it will not take effect until the acceleration phase is finished (temperature rises above the acceleration phase). If you want to manually control the power output during the entire boiling process, set **bAST** to zero (see section 6.3, note 7 for details).

5.3.2 Event timer

Multi-event timer is added to the boil mode (similar to Auber [JSL-73B](#), multi-event timer for beer brewing). This timer function will beep and pause for the duration programmed by the user. It lets the user know whether it is the time to add a specific ingredient. The programming of the timer follows the style of traditional beer recipe. If three ingredients need to be added at separate time during the boil process, it is considered as 3 events. Since most recipe tells you how long each ingredient needs to add (or how long from the end of process), instead of the time since the start of the boil process, the time value is also entered as in the recipe. The controller will convert the cook time of each ingredient to the time since the start of the boil. For timer details, please check section 6.3, note 8.

5.3.3 Keypad functions

If timer is disabled (tF = OFF), key A and B control the SSR power output. Press key A momentarily to enable the output, or restart from the STOP status. The bottom display will show "RUN" for a short moment. **Press key B momentarily to stop** the output. The bottom display will flash "STOP".

If timer is enabled (tF = ON), key A and B control the SSR power output and timer function. Press key A momentarily to enable the output, or resume/restart from the HOLD/STOP status. If PuS is set to "dely" (delayed power-up, note 2-2 in page 4), timer will be enabled at the same time. Press key B momentarily to hold the timer, but it will NOT hold the power output status. **Press and hold Key B for 5 seconds to stop** the timer and disable the power output. Bottom display will flash "STOP" and OUT indicator is OFF.

Note for mute function of Key A/RUN: Key A can also be used to mute the built-in buzzer when triggered by temperature alarm (relay mode ALbE only, note 12 in page 9). Once the built-in buzzer is turned on (triggered by temperature alarm), user can mute the built-in buzzer manually by pressing Key "A" (or "RUN") momentarily. This mute operation will not affect relay action nor mute step/timer event alarm notifications.

Key A can be used to start the program as well, but "mute" function has higher priority than "start" function: When process temperature is in the alarm zone and the program has not started yet, press Key A momentarily will mute the alarm first. To start the program, you need to press Key A again.

5.3.4 Criteria to start the timer in boiling mode

To start the timer, three criterions need to be met:

- 1). Timer must be enabled in parameter settings: tF = ON (note 9 in page 7)
- 2). The controller cannot be under STOP/HOLD status. If you see the display flashes "STOP" or "HOLD", you need to press key A momentarily to start or resume the program.
- 3). Controller's reading temperature (top display) must be higher than the value of btsp (boiling timer start temperature, note 9 in page 7).

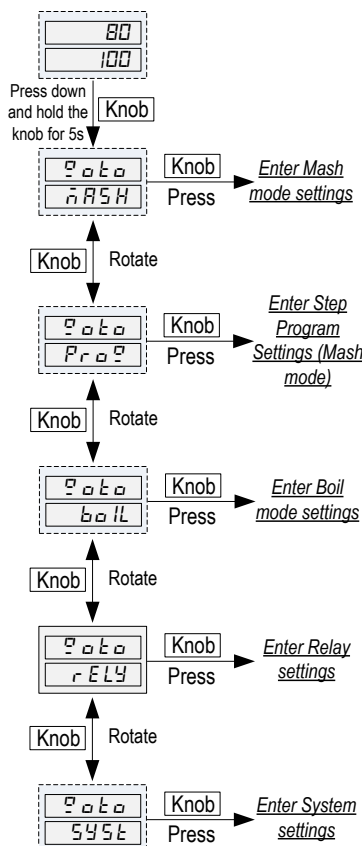

Figure 5. Parameter group selection

Tip 1: When timer is started, you will hear the beeping notification. Please see section 9 in page 10 for details.

Tip 2: Similar to mashing mode, you can even hold the timer (by pressing key B momentarily) before the timer is started (reading temp. is below btsp, note 9 in page 7). Then when reading temp. is over btsp, timer will be started and held immediately. You will hear the beeping notification. This tip can create one "HOLD" step before the timer is started.

6. Control Parameters

Parameters are divided into five groups (figure 5): **MASH** for step mashing control, **PROG** for step program settings for mashing, **BOIL** for boiling control, **RELY** for alarm relay settings and **SYST** for system configuration.

To enter parameter setting mode, press and hold the knob for at least 5s. Then you will see "GOTO" on the top display. Rotate the knob, you will see the bottom display changes with five different names: **MASH** (figure 5), **PROG** (figure 8), **BOIL** (figure 10), **RELY** (figure 11) and **SYST** (figure 6). All parameter values are stored in the controller memory, and they remain unchanged if you power it off.

Press down and hold the knob for 5s to enter the setting group selection. Bottom display is your current selected group. Press down the knob again to enter the selected parameter group. Then top display shows the current selected parameter name, and the bottom display shows its value/options. Rotate the knob clockwise to increase the value, and counter-clockwise to reduce the value. Fast rotating will change the value rapidly. Once finished, press knob again to confirm and go to next parameter. You can press the knob repeatedly to exit the setting quickly.

6.1 System settings (SYST)

System parameters that configure this controller are grouped under this menu.

Table 1. System configuration parameters.

System Configuration (SYST)					
Display	Code	Description	Setting Range	Initial Setting	Remark
Pb	Pb	Temp. reading offset	-20.0 ~ +20.0 °C or °F	0.0	Note 1
C-F	C-F	Temp. display unit	°C, °F	°F	Note 2-1
PuS	PuS	Power up settings	inst, dely	dely	Note 2-2

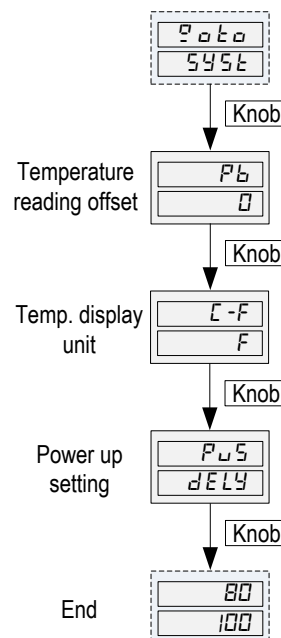

Figure 6. Flow chart of setting system parameters.

Note 1. Input offset: Pb

Pb is used to set an input offset to compensate the error produced by the sensor or input signal itself. For example, if the controller displays 2°C when probe is in ice/water mixture, setting Pb = -2.0, will make the controller display 0°C. The resolution for Pb is 0.1 °C or °F. It can be used to match its reading with other higher resolution thermometers.

Note 2-1. Temperature unit setting: C-F

C-F determines the temperature unit. It can be set to **C** (Celsius, °C) or **F** (Fahrenheit, °F).

Note 2-2. Power up settings: PuS

PuS determines the SSR power output status when the controller is powered up for both mashing and boiling modes. It can be set to **inst** (instant power-up) or **dely** (delayed power-up). If PuS is set to **dely** (by default), the bottom display will flash "stop" when the controller is powered up. The output is disabled. Press key A momentarily to start the program and enable the output. If PuS is set to **inst**, the program will be started when the controller is powered up. The output is enabled at same time automatically.

Tip: After you switch between mashing and boiling mode, the program will be stopped and bottom display will be flashing "stop".

6.2 Mashing Parameters (MASH)

Parameters the configure the step mashing control are grouped under this menu.

Table 2. Step mashing mode parameters.

Step Mashing Mode Parameters (MASH)					
Display	Code	Description	Setting Range	Initial Setting	Remark
tSP	tSP	Mashing timer starting temp.	-999~+9999 °C or °F	1	Note 3
EO	EO	Mashing ending options	ON, OFF	OFF	Note 4
oScr	oScr	Overshoot correction	-50~+50	0	Note 5-1
mOUT	mOUT	Mashing acceleration output power	0 ~ 100	100	Note 5-2
AttE	AttE	Attenuation constant	-2~+2	0	Note 5-1

Note 3: Mashing timer starting temperature: tSP

This parameter is defined as the temperature difference between the measured temperature (PV) and set temperature (SV), or deviation from the set point. Its default value is 1 degree. It means when program finished current step and start to heating at the maximum output power set by parameter mOUT (see note 5-2) to reach the next step, the timer will not start to count until the temperature is one degree below the set temperature of the next step. When the controller finished current step, the controller will make two short beeps, and another two short beeps after a second. Then, the controller will turn the heater to full power to reach the next set point.

During the heating up process, the bottom display will flash between the step number and set temperature alternately. The top display will display the current temperature. When the reading temperature reaches one degree below the set point, the controller will make three short beeps. Then the top display will start to display the current temperature and **the remaining time for the current step** alternately. In other word, the timer for step mashing mode is countdown timer.

Note 4: Timer Function: tSP, EO

When the program is "end" (please check section 5.2.2 for the difference between "end" and "stop"), the controller will generate six long beeps. The top display will switch between the current temperature and "End" alternately. After timer ends, the power output can be configured either to continue heating, or shut off. It is controlled by the parameter called **ending options for step mashing mode, EO**. Set it to **ON** for continue heating, set it to **OFF** to turn off the output.

Note 5-1: Temperature Control Tuning Parameters: oScr, AttE

The mashing control mode utilizes AI algorithm instead of the commonly used PID or ON/OFF control algorithm. The program is optimized for beer mashing. For most system, there is no need to tune. It allows the system to heat up at maximum speed, then hold the temperature stable with one-degree precision. If you are not satisfied with the control result, these two parameters will help you to fine tune the system. The **overshot correction, oScr** is for adjusting the temperature overshoot during the initial heat up. For example, if the temperature overshoot 3 degrees, set oScr = 3 to remove this overshoot. Some users may want to set oScr as negative number to purposely force a temperature overshoot, which can reduce the temperature response delay between the HLT and MLT. Please note oScr only affects the initial heating phase and also the transition phase between steps. It has no effect if the reading temperature is already settled at the current set temperature.

The **attenuation constant, AttE** is for adjusting the temperature stability during mashing. The value is from -2 to +2. The default value is 0. If the temperature fluctuates more than one degree, user can increase the value. If the controller takes too much time to correct the temperature drop, user can reduce the AttE to make the system more responsive.

Note 5-2: Mashing acceleration output power: mOUT

EZboil accelerates heating speed of the initial heating phase by running the heater at high power, then reduce the power once the temperature is getting close to the set temperature. The heating acceleration in mash mode is controlled by mashing acceleration output power, mOUT. It is the power used during initial heating phase and also the transition phase between steps. The unit is in percent of power from 0% to 100%. It should be set to 100% unless you want to manually adjust/reduce the power output during the initial heating phase. (For example, if you have a very powerful heater with very small amount of liquid.)

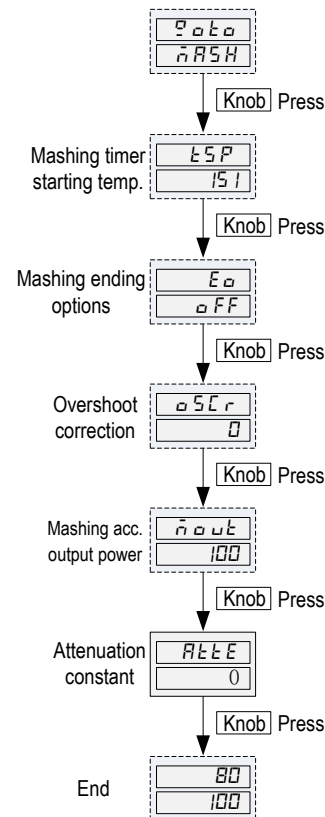

Figure 7. Flow chart of setting mashing parameters.

6.2 Step program settings for mashing (PROG)

Parameters for the step profile of mashing mode are grouped under this menu.

Table 3. Step program setting parameters

Step Program Settings for Mashing Mode (PROG)					
Display	Code	Description	Setting Range	Initial Setting	Remark
C-1	C-1	Step 1 set temperature	0 ~ 999	122	Note 6
t-1	t-1	Step 1 time duration	hold, stop 0 ~ 99:00	00:30	
C-2	C-2	Step 2 set temperature	0 ~ 999	140	
t-2	t-2	Step 2 time duration	hold, stop 0 ~ 99:00	00:20	
C-3	C-3	Step 3 set temperature	0 ~ 999	154	
t-3	t-3	Step 3 time duration	hold, stop 0 ~ 99:00	00:40	
C-4	C-4	Step 4 set temperature	0 ~ 999	168	
t-4	t-4	Step 4 time duration	hold, stop 0 ~ 99:00	00:15	
C-5	C-5	Step 5 set temperature	0 ~ 999	50	
t-5	t-5	Step 5 time duration	hold, stop 0 ~ 99:00	00:00	
C-6	C-6	Step 6 set temperature	0 ~ 999	50	
t-6	t-6	Step 6 time duration	hold, stop 0 ~ 99:00	00:00	
C-7	C-7	Step 7 set temperature	0 ~ 999	50	
t-7	t-7	Step 7 time duration	hold, stop 0 ~ 99:00	00:00	
C-8	C-8	Step 8 set temperature	0 ~ 999	50	
t-8	t-8	Step 8 time duration	hold, stop 0 ~ 99:00	00:00	

Note 6: Step program settings, C-1 ~ C-8, t-1 ~ t-8:

A total of 8 steps can be programmed in step mashing mode. Each step contains the set temperature (C-X) and the time duration for this step (t-X), where "X" is the step number (e.g. step 4 temperature is represented by C-4, and step 4 time is represented by t-4). Time starts counting when the reading temperature is tSP (section 6.2, note 3) degree below the set temperature in that step, and stops counting once time is up. Then it will jump to next step. The time unit is hour:minute (hh:mm) with 1 minute resolution. You can also set time to "hold", or "stop" by keep turning counterclockwise, until the reading is below the zero.

The initial step program for mashing:

Table 4. Default step program settings.

Parameter	Initial Setting
C-1	122
t-1	00:30
C-2	140
t-2	00:20
C-3	154
t-3	00:40
C-4	168
t-4	00:15
C-5	50
t-5	00:00
C-6	50
t-6	00:00
C-7	50
t-7	00:00
C-8	50
t-8	00:00

This program will control the temperature at 122F for 30 minutes. Then, change the temperature to 140F and hold for 20 minutes. Then change the temperature to 154F and hold for 40 minutes. Finally change the temperature to 168F and hold for 15 minutes. Then end the program (timer is set to 0 for step 5 and 6).

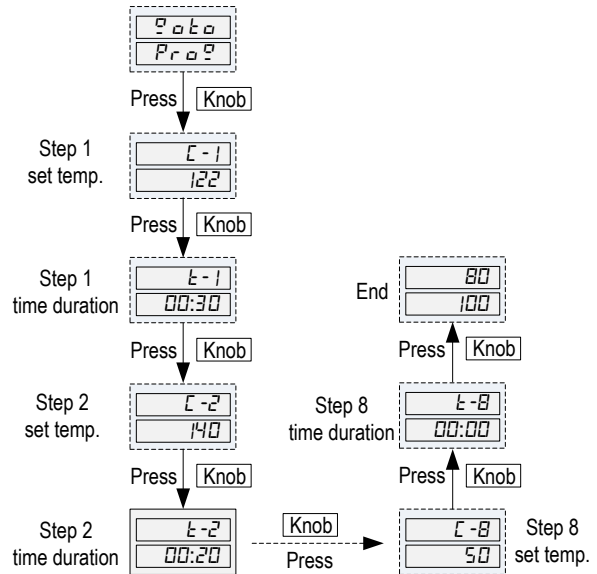

Figure 8. Flow chart of setting step program settings.

6.3 Boiling Parameters

Parameters the configure the boiling control are grouped under this menu.

For the easy of discussion, we divide the boiling mode into two phases, the **initial heating phase** and **boiling phase**. During the initial heating phase, power output is set high to accelerate the temperature rise. During the boiling phase, the power output is lowered to prevent the boiling over. We name the output setting for the boiling phase as "Boil Output" setting. Its value is always displayed on the bottom LED display and can be adjusted by turning the knob. The acceleration power output setting is not displayed at bottom display during initial heating, because it rarely set to less than 100%.

Table 5. Boiling mode parameters

Boiling Mode Parameters (BOIL)					
Display	Code	Description	Setting Range	Initial Setting	Remark
bAST	bAST	Boiling acceleration set temp.	-999 ~ +9999°C or °F	200	Note 7
bOUT	bOUT	Boiling acceleration output power	0 ~ 100%	100	
nE	nE	Total number of timer events	1 ~ 9	3	Note 8
Bot1	Bot1	Event 1 timer	0 ~ 99:59	01:00	
Bot2	Bot2	Event 2 timer	0 ~ 99:59	00:20	
Bot3	Bot3	Event 3 timer	0 ~ 99:59	00:01	
btSP	btSP	Boiling timer start temp.	-999~+9999 °C or °F	208	Note 9
Ad	Ad	Alarm duration for boil mode	0 ~ 200	10	Note 10
bEO	bEO	Boiling ending options	ON, OFF	OFF	Note 9
tF	tF	Timer function for boil mode	ON, OFF	ON	Note 9

Note 7: Acceleration heating function: bAST, bOUT

EZboil accelerates heating speed of the initial heating phase by running the heater at high power, then reduce the power once the temperature is getting close to the boil. The heating acceleration in boiling mode is controlled by two parameters, **Boiling acceleration set temperature, bAST** and **Boiling acceleration output power, bOUT**. The bAST set the temperature limit that below this temperature, the controller will output at a power determined by the bOUT. When temperature rise to the bAST, the output will automatically reduce to a lower level to prevent a messy boiling over. The boiling over is caused by several factors including the amount of foam on the surface and the power of the

heater. The more foams there is, the easier it is to boil over. The vigorous the boil is, the easy it is to boil over. To preventing the boiling over, operator should skim the foam out and reduce the power as the temperature approaching the boiling. Since the heater power and liquid volume varies between each application, we suggest the bAST to be set at least 5 degree (Fahrenheit) below the boiling point for the first time use. As you getting familiar with your system, you can change this setting to higher or lower. The bOUT is the power used during initial heating phase. The unit is in percent of power. It should be set to 100% unless you have a very powerful heater with very small amount of liquid. The bOUT setting does not limit the power regulation range for boiling phase. **If you don't need to use this feature, set bAST to 0, so this controller will work as a manual mode controller over the entire temperature range.**

Note 8: Timer and event settings (boil mode): nE, bot1 ~ bot9

A timer event is defined as an action of adding an ingredient at a specific time point during the wort boiling process. An event timer starts from the moment that the ingredient is being added to the wort; it stops when the wort-boiling process comes to an end. There can be multiple events during the wort-boiling process. Each event should have a different starting time point, but they all end at the same time, which is when the boiling process ends.

To start activate the timer event, you need to 1) change the timer status from "stop" to "run" by pressing Key A momentarily. 2) the reading temperature must be higher than btSP (section 6.3, note 9). When the timer starts, the top display will show the reading temperature and total the remaining time (before the end of last event) alternately. The temperature and time display can be easily differentiated with their appearance. The temperature and time display has two or three digits. For example, 212 degrees will be displayed as "212". The timer display has four digits with flashing colon in the middle. For example, "01:20" for 1 hour 20 minutes. The bottom display will show the power output percentage and current step number (e.g. P-1 for step 1) alternately.

Please see Figure 9 for a schematic diagram showing the relationship between multiple events and the alarm relay status.

nE, total number of timer events. An event can be associated with an activity such as adding hops or special ingredients. Each event has its own timer. nE can be set to a number from 1 to 9. The built-in buzzer will be triggered at the beginning of all events except the first event, and at the end of the entire boiling process. So nE is equal to the total number of times you want the buzzer to ring. You can also set the external relay synchronized with the built-in buzzer (section 6.4.2, note 12). For example, if you only add one hop at the very beginning of the boiling process, and add another hop in the middle of boiling, which is considered as the second event, you need to set nE = 2, and the buzzer will go off when the second event starts.

Event timer: botX (i.e. bot1, bot2, bot3, ..., botX), the time duration of each event, where X is the event number (1 ~ 9). X is decided by parameter nE. Time duration of an event, botX, is the boiling time of an ingredient to be added to the boiling wort. bot1 is the first event timer which starts from the moment that the first ingredient is added until the end of boiling, bot2 is the second event timer which starts when the second ingredient is added until the end of boiling, and so on. The buzzer will be triggered at the beginning of all event timers (bot1, bot2, ..., bot9). The buzzer will be also triggered when all the event timers are ended.

An event timer that starts later should be no longer then the event timers that start earlier, i.e., bot1 ≥ bot2 ≥ bot3 ≥ ... ≥ botX. When an event timer is equal to its prior event timer, this event timer will be ignored. For example, if you set bot1 = bot2, timer bot2 will be ignored.

Example: If the first ingredient (bot1) needs 60 minutes, the second ingredient (bot2) needs 10 minutes and third ingredient (bot3) needs 1 minutes of boil, you set Bot1 = 1:00, Bot2 = 00:10, Bot3 = 00:01. Assuming the timer will start at 0 minute (add first ingredient here). 50th minute from the beginning, controller will beep and let you add second ingredient. 59th minute from the beginning, controller will beep again to remind you it is the time to add the third ingredient.

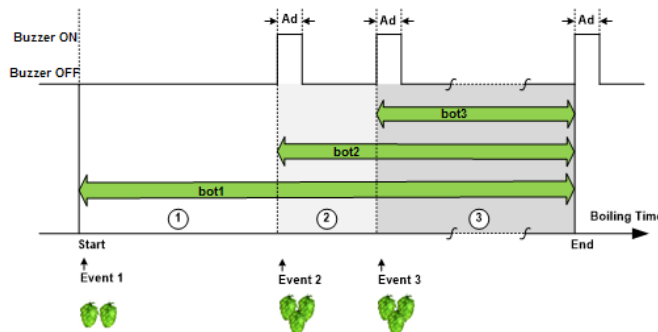

Figure 9. A schematic diagram of how the event timers and built-in buzzer work (nE = 3).

Note 9: Boiling mode timer function: tF, btSP, bEO

tF. The timer event function (for boil mode) is controlled by a master parameter tF. When it is set to ON, the timer event function for boiling mode is enabled. When tF is set to OFF, the timer function for boiling mode is disabled. When timer function is enabled, the timer counting will be started by timer start temperature, btSP. When reading temperature reaches timer start temperature, the timer starts to count, and the controller will generate three short beeps. After timer started counting, it will continue even if the temperature drops below this start temperature. The timer can be reset to start from beginning again. To reset the timer, press the knob momentarily, the display will show rSt on top and "n" at the bottom, rotate the dial clockwise will change the bottom display to "y". Press the knob again to reset the timer.

When time counting ends, the controller will generate eight long beeps. Both displays will flash "End" alternately. After timer ends, the power output can be configured either to continue heating, or shut off. It is controlled by the parameter called ending options for boiling mode, bEO. Set it to ON for continue heating, set it to OFF to turn off the output.

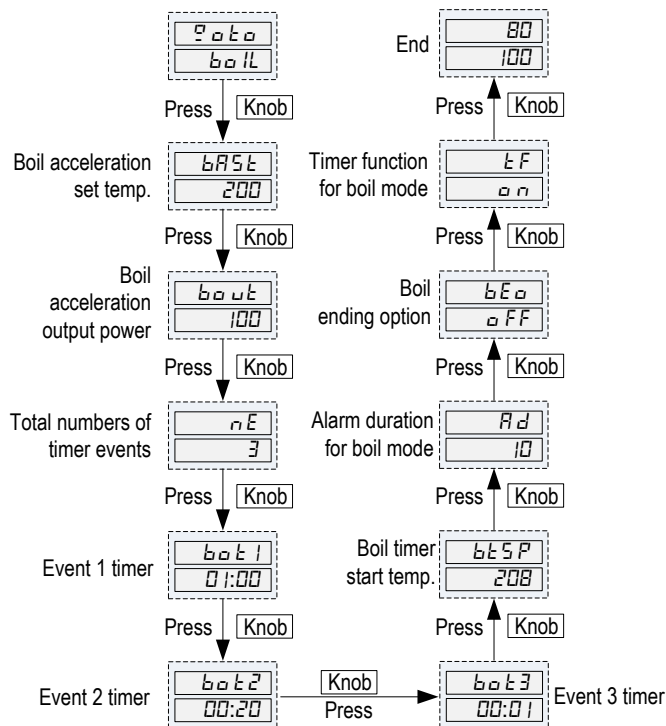

Figure 10. Flow chart for boiling mode settings

Note 10: Alarm duration for boil mode: Ad

Ad is the parameter that set how long the timer will hold for adding the ingredient. If you set it for 10, it will hold the timer for 10 seconds at the event which allows you to add ingredient. During this holding period, the buzzer will keep beeping, and timer will stop counting. You can also set Ad to 0, which will pause the timer at that event. You need to press the Key A to manually resume the timer.

6.4 External Relay Settings (RELY)

6.4.1 Introductory

This controller contains two normally open (N.O.) relays that can be used for controlling external devices such as buzzers, contactors, and valves. The relays are dry switches that can handle up to 3 Amps of resistive load or up to 1 Amp of inductive load. These relays can be programmed as process (absolute) alarms or act in synchronization with controller's mashing steps, boiling timer events as well as the built-in buzzer condition. There are a few advanced features of these relays. The relays can be set either to close the contacts, or to open the contacts when alarm condition meets.

6.4.2 Relay parameter settings

Parameters the configure the relays are grouped under this menu.

Table 6. Relay parameters

Relay Parameters (RELY)					
Display	Code	Description	Setting Range	Initial Setting	Remark
r L 1	RL1	Relay 1 mode	Off, ALAM, B-SN, M-SN, beep, ALbE	Off	Note 11
L g C 1	Lgc1	Logic mode for relay 1	RL_C, RL_O	RL_C	Note 12
r L P 1	rLP1	Relay turning-on steps	0 ~ 511	0	Note 13
L R E 1	LA1	Pulse action for relay 1	PUL, N	N	Note 14.1
S I L 1	SiL1	Alarm suppression for relay 1	ON, OFF	OFF	Note 14.2
A H 1	AH1	Alarm 1 high limit	OFF, 1 ~ 999	OFF	Note 14.3
A L 1	AL1	Alarm 1 low limit	OFF, 1 ~ 999	OFF	Note 14.4
H Y 1	HY1	Alarm 1 hysteresis band	0.1-100.0	0.3	Note 14.5
A P 1	AP1	Alarm 1 pulse length	1-100	5	Note 14.6
r L 2	RL2	Relay 2 mode	Off, ALAM, B-SN, M-SN, Beep, ALbE	Off	Note 11
L g C 2	Lgc2	Logic mode for relay 2	RL_C, RL_O	RL_C	Note 12
r L P 2	rLP2	Relay turning-on steps	0 ~ 511	0	Note 13
L R E 2	LA2	Pulse action for relay 2	PUL, N	N	Note 14.1
S I L 2	SiL2	Alarm suppression for relay 2	ON, OFF	OFF	Note 14.2
A H 2	AH2	Alarm 2 high limit	OFF, 1 ~ 999	OFF	Note 14.3
A L 2	AL2	Alarm 2 low limit	OFF, 1 ~ 999	OFF	Note 14.4
H Y 2	HY2	Alarm 2 hysteresis band	0.1-100.0	0.3	Note 14.5
A P 2	AP2	Alarm 2 pulse length	1-100	5	Note 14.6

Note 12: RL (Relay Mode), determines which mode a relay should be working at. **RL1** is for Relay 1 and **RL2** is for Relay 2. Each relay has five modes:

Off: This relay function is disabled.

ALAM: In this mode, relay is set as Process Alarm. It can either be triggered by a process high alarm, by a process low alarm, or by both. Parameter AH, AL and HY are used to set the on/off temperature for this relay output. Check note 14.5 for details.

M-SN. In this mode, relay is synchronized with mashing steps. This relay can be programmed to be activated at target mashing step or steps. For example, user can program it to turn on during step 1, 4 and 6. Parameter rLP is used for programming (see below).

B-SN: In this mode, relay is synchronized with boiling steps. Similar to M-SN, this relay can be programmed to be activated at target boiling step or steps. Parameter rLP is used for programming (see below).

Beep. In this mode, relay is synchronized with internal buzzer. When the built-in buzzer beeps, this relay also turns on. This will allow the user to drive an external flashing buzzer for louder and visual notification.

ALbE. "Alarm and beep" mode. Take relay 1 as an example (relay 2 works the same). When the RL1 is set for ALbE, the internal buzzer not only beeps for each step/timer event (as **Beep** mode), but also when temperature alarm 1 condition is met (AH1, AL1, HY1, AP1). Relay 1 output will be activated at same time. This parameter enables the usage of internal buzzer for temperature alarm. It is a useful feature for small control panel that has no place for an external buzzer.

Note for ALbE and Beep modes: ALbE mode is different than Beep mode. When RL1 is set to **Beep**, the relay output acts synchronously with the built-in buzzer. The built-in buzzer and relay output only work as event notification, and they cannot be set as temperature alarm. When RL1 is set to **ALbE**, the built-in buzzer will work for both temperature alarm and event notification. The relay output will work as temperature alarm only.

Note 12: Lgc (Relay Logic), determines relay status before and after the alarm conditions are met. It can be set to Logic Close (**RL-C**) or Logic Open (**RL-O**). When a relay is set to **RL-C**, the relay is a NO relay, it stays open when it is inactive; the relay contacts close (pull-in) when alarm conditions are met. When a relay is set to **RL-O**, the relay is essentially a NC relay, it stays closed when it is inactive; the relay contacts open up (drop-out) when alarm conditions are met. For most applications, the relay should be set to Logic Close (**RL-C**), which is the default setting. The Logic Open (**RL-O**) configuration is useful if user want to turn on a device when the temperature is not in the alarm zone.

Note 13: rLP (Relay turning-on steps)

Those two parameters determine which steps to turn on the R1 and R2 relays respectively. The value is determined by the following formula. **Or you can use the relay setting calculator [here](#).**

$$rLP \text{ (mashing mode)} = A * 1 + B * 2 + C * 4 + D * 8 + E * 16 + F * 32 + G * 64 + H * 128;$$

$$\text{or } rLP \text{ (boiling mode)} = A * 1 + B * 2 + C * 4 + D * 8 + E * 16 + F * 32 + G * 64 + H * 128 + I * 256;$$

Where,

- If A = 0, then relay is open at step/event 1.
- If A = 1, then relay is closed at step/event 1.
- If B = 0, then relay is open at step/event 2.
- If B = 1, then relay is closed at step/event 2.
- If C = 0, then relay is open at step/event 3.
- If C = 1, then relay is closed at step/event 3.
- If D = 0, then relay is open at step/event 4.
- If D = 1, then relay is closed at step/event 4.
- If E = 0, then relay is open at step/event 5.
- If E = 1, then relay is closed at step/event 5.
- If F = 0, then relay is open at step/event 6.
- If F = 1, then relay is closed at step/event 6.
- If G = 0, then relay is open at step/event 7.
- If G = 1, then relay is closed at step/event 7.
- If H = 0, then relay is open at step/event 8.
- If H = 1, then relay is closed at step/event 8.
- If I = 0, then relay is open at event 9.
- If I = 1, then relay is closed at event 9.

The minimum rLP value is 0. The maximum rLP value is 255 for step mashing mode (up to 8 steps can be programmed, if relay is ON for all 8 steps), and 511 for boiling mode (up to 9 timer events can be programmed, if relay is ON for all 9 events).

Note for mashing mode: If you set to turn on the relay at step 1 only, relay will be activated when you start the whole program (when you press key A), and will be deactivated when step 1 is finished. It doesn't affect if the timer in step mashing mode has not been started yet. If you set to turn on the relay at other step, relay will be activated from the moment when the previous step is finished, to the moment when the current step is finished. If you set to turn on the relay at continuous steps (for example, step 2 and 3), the relay will remain at ON position during the transition period(s) between steps.

For example, if you set relay 1 is synchronized with mashing steps (LP1 = M-SN), and if you set to turn on relay 1 at step 1 & 2 only (rLP1 = 3), once you press the key A to start the program, relay 1 will be turned ON immediately (even the step timer has not been started yet). Relay 1 will remain at ON position during the transition period between step 1 and step 2 (where there might be a timer gap/acceleration period). When the controller has finished step 2, relay 1 will be OFF immediately (you will hear the four 2s long beeping to alert you the current step is finished). In other word, the relay 1 will be turned on from the moment when you press key A to start the whole program, to the moment when step 2 has been finished.

Note for boiling mode: The definition for timer event here (for rLP calculation) is different than the timer event in boiling mode (section 6.3). The timer event here is the interval time from the beginning of current timer event to the beginning of next timer event (like mashing mode). Current event doesn't include the time of next event.

Example: If the first ingredient (bot1) needs 60 minutes, the second ingredient (bot2) needs 10 minutes and third ingredient (bot3) needs 1 minutes of boil, you set Bot1 = 1:00, Bot2 = 00:10, Bot3 = 00:01. The event 1 for relay is the time from 00:00 to 00:50 (if counting up) or 1:00 to 00:10 (if counting down). Event 2 for relay is the time from 00:50 to 00:59 (if counting up) or 00:10 to 00:01 (if counting down). Event 3 for relay is the time from 00:59 to 01:00 (if counting up) or 00:01 to 00:00 (if counting down). If you set relay 2 for B-SN, and if you set rLP2 to 2, relay 2 will be activated during event 2 for relay only, which is the time from 00:50 to 00:59 (if counting up) or 00:10 to 00:01 (if counting down).

Calculation Example:

a) To turn on relay 1 on step/event 2 and step/event 3 only, rLP1 needs to be set to 6:

$$rLP1 = 0*1 + 1*2 + 1*4 + 0*8 + 0*16 + 0*32 + 0*64 + 0*128 + 0*256 = 6$$

b) To turn on relay 2 from step/event 1 to step/event 5, rLP2 needs to be set to 31:

$$rLP2 = 1*1 + 1*2 + 1*4 + 1*8 + 1*16 + 0*32 + 0*64 + 0*128 + 0*256 = 31$$

Note 14: Settings for Process Alarm (rL = ALM or ALbE)

The following parameters are only applicable if this relay is set to process alarm (rL = ALM or ALbE): LAt, SiL, AH, AL, HY and AP2

Note 14.1: LAt (Relay Action, rL = ALM/ALbE only), determines the relay actions when alarm conditions are met and/or then removed. It can be set to PUL for pulsing mode, or N for Normal Mode.

When LAt is set to PUL (Pulsing Mode, rL = ALM/ALbE only), the replay action is a timed single pulse. When the alarm condition is met, relay will be activated only for a pre-determined period of time. User can set the pulse duration by the AP parameter in the menu of alarm settings; it ranges from 1 to 100 seconds. This feature is useful in situations where a user only need to ring the buzzer for a short time or want to drive an external load for a fixed amount of time duration.

When LAt it is set to N (Non-Latching, rL = ALM/ALbE only), the relay action will follow the alarm condition. The relay stops its action when the alarm condition is removed.

Note 14.2: SiL (Relay Silence, also called Alarm Suppression, rL = ALM/ALbE only),

SiL determines whether a relay action should be suppressed when controller is just powered up. Relay Silence/Alarm Suppression is only supposed to work when: 1) absolute low alarm is enabled and 2) the reading temperature is never over (AL + Hy) after power up. If the reading temperature has been over (AL + Hy), once the reading temperature drops below AL, the alarm will be ON and alarm suppression will be disabled.

This feature is useful for the following situation: when a relay is set as low limit alarm, and you don't want the relay to pull in when you just power up the controller as the start-up temperature will be in the alarm zone.

Note 14.3: AH (High Alarm, rL = ALM/ALbE only), determines at what temperature that is higher than the set temperature the alarm relay will be activated. This setting applies to both process and derivation alarms. The unit is in degree C or F. AH1 is for Relay 1 and AH2 for Relay 2. It can be set to any temperature that the controller is capable to reading, or set to "off". The value of AH represents the absolute high alarm. The relay will be activated when PV > AH, and deactivated when PV < (AH - HY).

Note 14.4: AL (Low Alarm, rL = ALM/ALbE only), determines at what temperature that is lower than the set temperature the alarm relay will be activated. This setting applies to both process and derivation alarms. The unit is in degree C or F. It can be set to any temperature that the controller is capable of reading, or set to "off". The value of AL represents the absolute low alarm. The relay will be activated when PV < AL, and deactivated when PV > (AL + HY).

Tip 1: AL should always be less than AH (AL1 < AH1, AL2 < AH2), otherwise, the alarm relay will stay activated all the time.

Tip 2: A relay can be set to work for process high alarm only (i.e., set AL = off), for process low alarm only (i.e., set AH = off), or for both high and low alarm.

Note 14.5: HY (Hysteresis Band, rL = ALM/ALbE only), determines the hysteresis band between temperature of activating and deactivating alarms. It is also called differential band by some manufacturer. The unit is degree F or C. For example, Relay 1 is set as a non-latching process alarm with relays settings RL1 = ALM, Lgc1 = RL_C, LAt1 = N, AH1 = 200, AL1 = 100 and HY = 3 (temperature unit is F). For the high limit alarm, when the process temperature is greater and equal to 200°F, the relay will pull in; and when process temperature drops off below 197°F, relay will drop off. For the low limit alarm, relay will pull in when process temperature is less than 100°F; and the relay will drop off when process temperature is greater to 103°F.

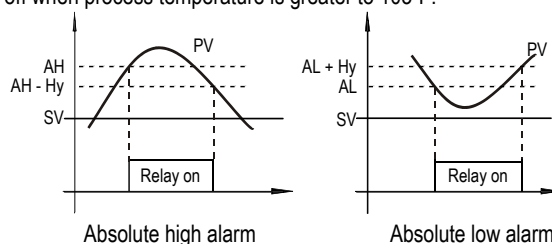

Figure 12. Relationship between Hy and high/low absolute alarm

Note 14.6: AP (Alarm Pulse, rL = ALM/ALbE only), determines the time duration of which a relay stays activated. The unit is second. Pulse length can be set from 1 to 100 seconds.

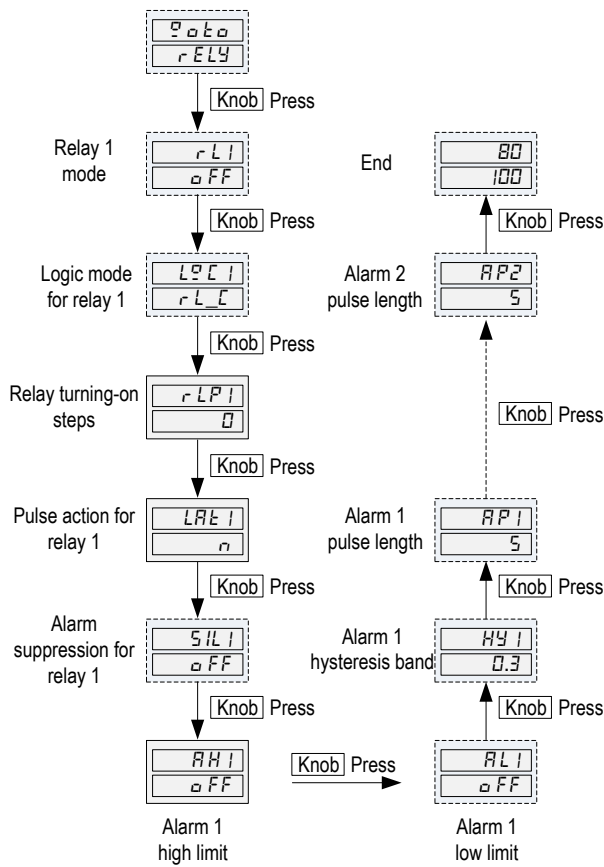

Figure 11. Flow chart for relay parameter settings

7. Application Examples

1) Use DSPR310D under single step mashing mode (similar to DSPR300)

Set the parameter as following:
 Under PROG menu, set C - 1 as your mash temperature (like 122F), t - 1 to a large time like 99:00; set all unused t - 2 ~ t - 6 to 00:00. Under MASH menu, set EO to OFF.

Once powered up, this controller will maintain at the temperature of C - 1 for a long time. You can manually end this process by press and hold Key B, or simply turn off the controller.

2) Use DSPR310D as a manual power regulator (similar to DSPR1)

Set the parameter as following:

Mode = boil, tF = off, bAST = 0

To use it as manual regulator with temperature reading, please set it to boiling mode. Disable timer event, and set boiling acceleration set temperature below ambient temperature (or just zero).

8. Wiring Examples

Example 1. Here are two wiring diagrams of how to connect a DC triggered AC SSR with this power regulator.

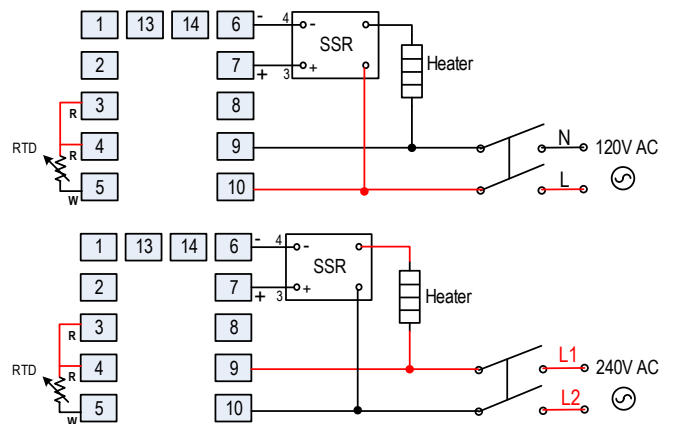

Figure 13. Wiring examples of controlling a heater with SSR and DSPR310D in a 120VAC system (upper) and in a 240VAC system (lower).

Example 2. Here is the wiring diagram of how to wire two external buzzers to the controller.

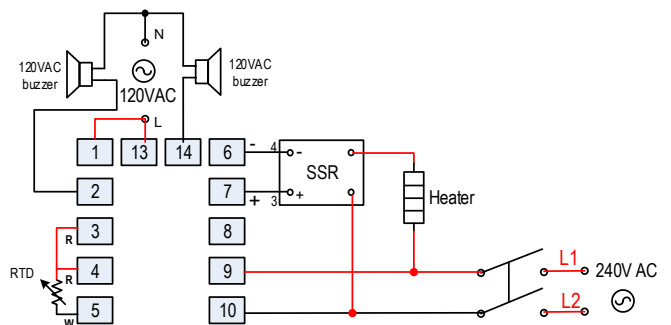

Figure 15. Wiring example of external buzzers. Power supply for the controller and heater is 240V AC. Power supply for two buzzers is 120V AC. AL1 buzzer is for absolute temperature alarm. AL2 buzzer is for step alarm.

9. Beeping sound definition:

The pattern of the beeping sound for each condition is different. This section will help user to tell what is the beeping for:

Legend:

- 1s short beep
- 2s long beep
- 5s long beep
- 1s short pause
- 2s long pause

Step mashing mode:

- 1) Four 2s long beeps (---•---•---•---): It is separated by a 1s short pause, a 2s long pause and another 1s short pause. It indicates that current step is finished. Starting to heat up for the next step.
- 2) Three 1s short beeps (-•-•-): It indicates that the current mashing step has started. The reading temperature has reached timer starting set point.
- 3) Eight 5s long beeps (-----•-----•-----
 ••-----••-----••-----
 ••-----): It indicates the whole program has ended. Both display will flash "end".

Boiling mode:

- 1) Four 2s long beeps (---•---•---•---): It is separated by a 1s short pause, a 2s long pause and another 1s short pause. It indicates that timer has

reached a timer event. It will continue this beeping pattern until the time duration programmed by parameter Ad has been reached.

2) Three 1s short beeps (—●—●—): It indicates first event timer has started. The reading temperature has reached timer starting set point, btSP.

3) Eight 5s long beeps (----- ●●----- ●●-----
●●----- ●●----- ●●----- ●●-----
●●-----): It indicates the whole program has ended. Both display will flash "end".

10. Common sensor errors:

This regulator will display error message or incorrect temperature reading if your sensor is not connected, or your sensor is bad. Top display will flash "orAL" and "932" alternately, if you set it to Fahrenheit display (C-F = °F); or "orAL" and "500" alternately, if you set it to Celsius display (C-F = °C).

Auber Instruments

5755 North Point Parkway, Suite 99

Alpharetta, GA 30022

www.auberins.com

Email: info@auberins.com Tel: 770-569-8420

Copyright 2007-2018, Auber Instruments All Rights Reserved.
No part of this manual shall be copied, reproduced, or transmitted in any way without the prior, written consent of Auber Instruments. Auber Instruments retains the exclusive rights to all information included in this document.

Appendix

Technical Talk -- How does it Work? v1.2

There are three commonly used methods for AC power control.

1) **Phase angle firing.** In this method, the AC power control is achieved by firing the SCR at different phase angle. This is how our SSVR works. This method offer the most uniform power output. But the output is very difficult to be adjusted linearly due to the shape of the sine wave. Because of the sharp cut off, there is a potential electromagnetic interference (EMI or RFI) if there are inductive devices on the power line. Some of the inductive devices cannot be controlled by this method.

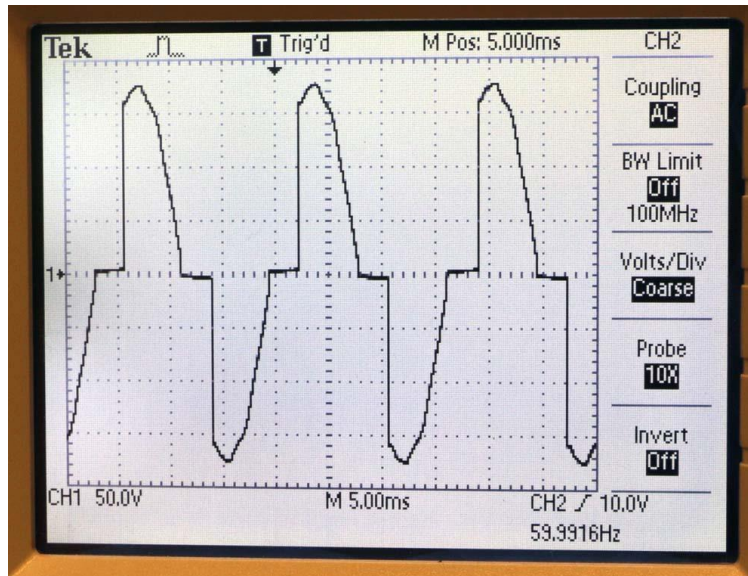

Figure 4. SSVR and TRIAC use phase-angle firing to regulate the power.

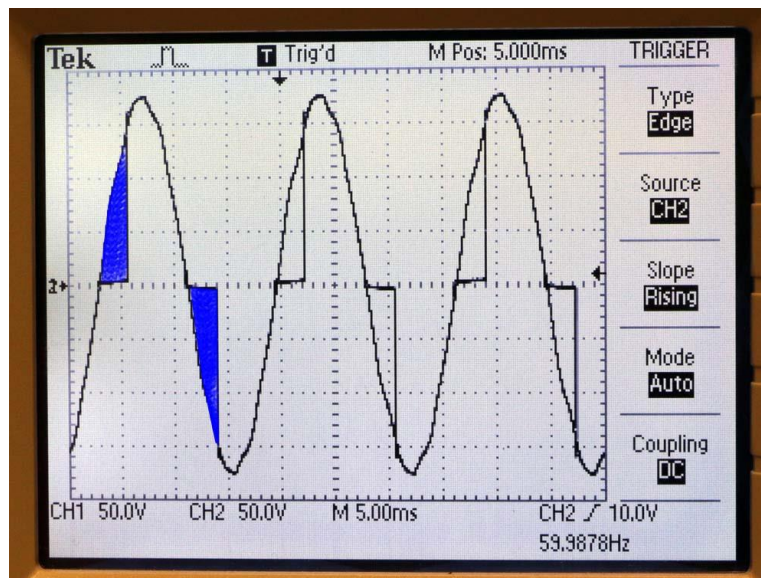

Figure 5. Original AC sine wave is overlaid with SSVR output wave form. The blue colored area shows the power output that has been blocked.

2) **Time proportional firing.** A fixed cycle time needs to be defined in this method. Then, the controller or regulator adjusts the on time during each cycle to achieve the power control. For example, if the cycle time is 1 second, turn on the power for 0.25 second for every 1 second means a 25% power output. Most of PID controllers use this method to control SSRs. This is also how the manual mode of Auber's PID controller works, except the cycle time has to be 2 second or longer. Using this method, the user can linearly adjust output. But the power output is pulsed at each cycle. The shortest cycle time for most PID is either 1 or 2 second. Therefore, power is pulsed at 1 or 2 seconds. When heating a liquid, heat is not transferred as smooth as the phase-angle fire method.

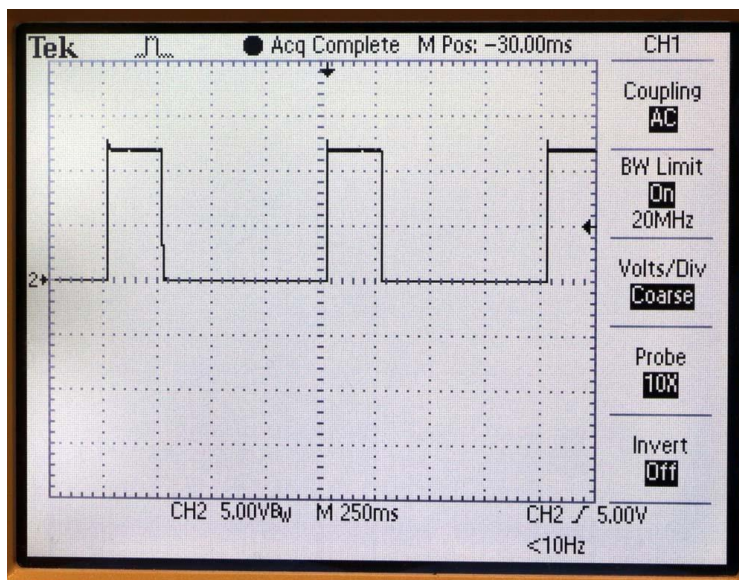

Figure 6. A 25% output control signal from a PID controller in the time proportional firing mode. Cycle time is 1 second. The output signal is 250 millisecond (ms) on, and 750 ms off during each cycle period.

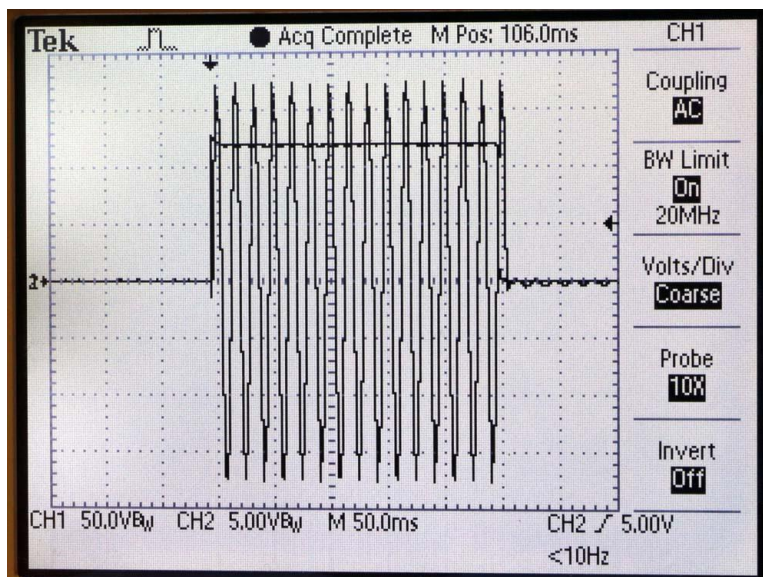

Figure 7. The control signal and SSR output waveform overlaid. When the DC signal (Channel 2, square wave) is on, the AC power can go through (Channel 1). When the DC signal drop to zero, the AC power is blocked.

3) **Burst firing.** This method is similar to time proportional firing (section 2). But in contrast to the time proportional mode, where the SSR is fired once for each fixed cycle period (which are usually 2 seconds or longer), the regulator will find the minimum cycle time to achieve the desired output percentage. The on pulse can be as short as one AC cycle. So power is distributed more evenly over cycle time. This leads to of a more uniform power output. Several PID controllers on the market use this mode. Our DSPR/EZboil also uses this approach as the default mode to regulate power.

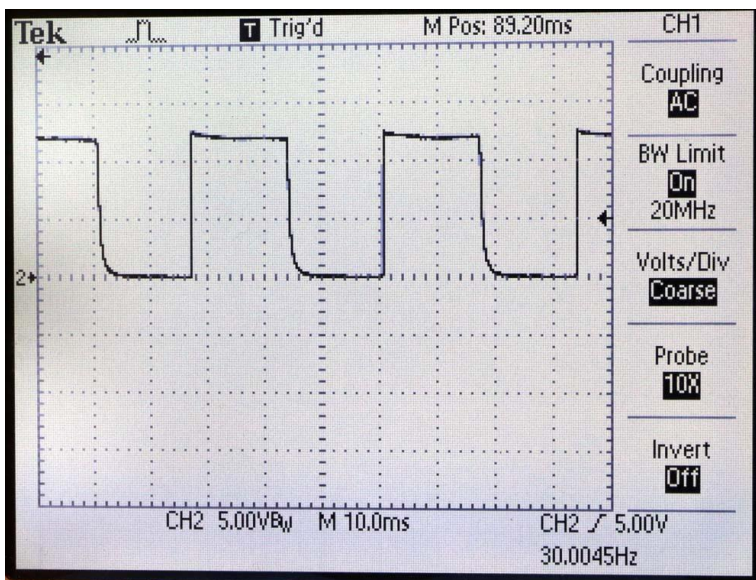

Figure 8. A 50% output control signal from DSPR when it is operating in the bust firing mode. Each pulse is 16.67 ms long, which is the same as a 60 Hz AC cycle. So one pulse on and one pulse cycle off is equal to 50% output.

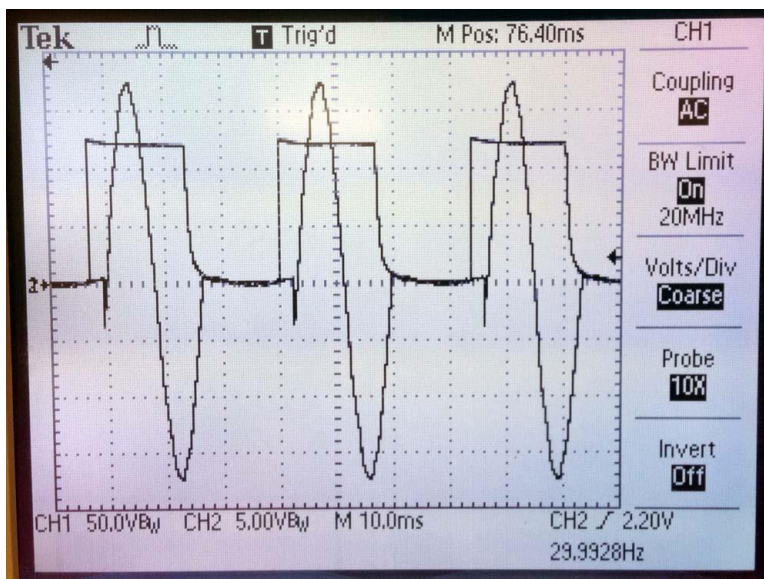

Figure 9. The DSPR control signal and SSR output waveform overlaid. The DSPR detects the frequency and phase of the AC power line, so that the pulse width and firing time is synchronized with AC cycle.

Auber Instruments

5755 North Point Parkway, Suite 99
 Alpharetta, GA 30022
www.auberins.com

Email: info@auberins.com Tel: 770-569-8420

Copyright 2007-2018, Auber Instruments All Rights Reserved.

No part of this manual shall be copied, reproduced, or transmitted in any way without the prior, written consent of Auber Instruments. Auber Instruments retains the exclusive rights to all information included in this document.