

**Instruction Manual**

**SYL-1512A2 PID TEMPERATURE CONTROLLER  
INSTRUCTION MANUAL**

Version 2.11 (June, 2015)

**⚠ Caution**

- This controller is intended to control equipment under normal operating conditions. If failure or malfunction of it could lead to an abnormal operating condition that could cause personal injury or damage to the equipment or other property, other devices (limit or safety controls) or systems (alarm or supervisory) intended to warn of or protect against failure or malfunction of the controller must be incorporated into and maintained as part of the control system.
- Installing the rubber gasket supplied will protect the controller front panel from dust and water splash (IP54 rating). Additional protection is needed for higher IP rating.
- This controller carries a 90-day warranty. This warranty is limited to the controller only.

**1. Specification**

<b>Input type</b>	Thermocouple (TC): K, E, S, R, J, T, B, WRe3/25 RTD (Resistance Temperature Detector): Pt100, Cu50
<b>Input range</b>	See table 2
<b>Display</b>	One line, four digits, °C or °F
<b>Display resolution</b>	1°C, 1°F; or 0.1°C, 0.1°F with Pt100
<b>Accuracy</b>	±0.2% or ±1 unit of full input range
<b>Control mode</b>	PID, On-off, Limit
<b>Output mode</b>	Relay contact: 3A at 240VAC, SSR: 8VDC, 40mA
<b>Alarm</b>	Process high/low alarm
<b>Power consumption</b>	< 2Watt
<b>Power supply</b>	85~260VAC/50~60Hz or 85-260VDC
<b>Dimension</b>	24 x 48 x 75mm (1/32DIN)
<b>Mounting cutout</b>	22 x 45mm

**2. Front Panel and Operation**

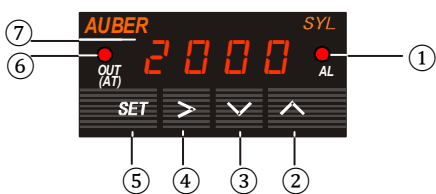

Figure 1. Front panel

- ① AL- Alarm/Relay J1 output indicator
- ② Value increment/Select next parameter
- ③ Value decrement /Select previous parameter
- ④ Auto tuning /Digit shift/Alarm mute
- ⑤ Set/Confirm/Control start (For limit control mode, press it for 5 seconds)
- ⑥ OUT- SSR output indicator /(AT) - blinking during auto-tuning process
- ⑦ The temperature of the probe (Process Value, or PV) is displayed during operation. The target temperature (Set Value or SV) is displayed when flashing (by press the ^ or V key once). The parameters value is displayed during controller set up.

**3. Terminal Wiring (back view)**

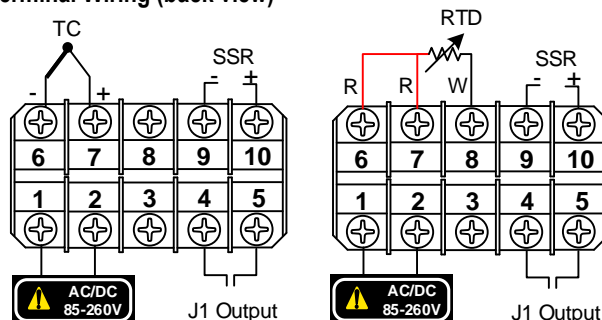

Figure 2. Wiring diagram with thermocouple input on the left and RTD input on the right

**3.1 Sensor connection**

**3.1.1 Thermocouple**

The thermocouple should be connected to terminals 6 and 7. Make sure that the polarity is correct. There are two commonly used color codes for the K type thermocouple: US color code uses yellow (positive) and red (negative). Imported DIN color code uses red (positive) and green/blue (negative). The temperature reading will decrease as temperature increases, if the connection is reversed.

**3.1.2 RTD sensor**

For a three-wire RTD with standard DIN color code, the two red wires should be connected to the terminals 6 and 7. The white wire should be connected to terminal 8. For a two-wire RTD, the wires should be connected to terminals 7 and 8. Jump a wire between terminals 6 and 7. Set controller input type, Inty, to P100 (1° resolution) or P10.0 (0.1° resolution).

**3.2 Power to the controller**

The power cables should be connected to terminals 1 and 2. Polarity does not matter. It can be powered by 85 - 260V AC or DC power source. Neither a transformer nor jumper is needed to wire it up. For the sake of consistency with the wiring example described later, we suggest you connect the hot wire to terminal 2 and neutral wire to terminal 1. Since the controller is in a plastic shell, ground wire is unnecessary.

**3.3 Output connection**

Two control output options are offered by this controller. (1) The SSR control output provides an 8VDC signal that can control up to 4 x SSRs in parallel. (2) The J1 relay output can be used to turn on a contactor or a solenoid valve. It can also drive a small heater directly if the heater draws <3A current. If the SSR control output option is selected, J1 can be used as alarm output.

**3.3.1. Connecting the load through SSR**

Connect terminal 9 to the negative input and terminal 10 to the positive input of the SSR. Set the system output configuration, outy, to 2, 3 or 6 - depending on the control mode used. See Figure 12 for details.

**3.3.2 Connecting the load through a contactor**

Assuming the controller is powered by a 120V AC source and the contactor has a 120V AC coil, jump a wire between terminal 2 and 4. Connect terminal 5 to one lead of the coil and terminal 1 to the other lead of the coil. Set the system output configuration, outy, to 1, 4, or 5 - depending on the control mode used. See Figure 11 and 13 for details.

**Note:** For first time users without prior experience with PID controllers, the following notes may prevent you from making common mistakes:

3.4.1 Power to the heater does not flow through terminal 1 and 2 of the controller. The controller consumes less than 2 watts of power. It only provides a control signal to the relay. Therefore, 20 gauge wires are sufficient for providing power to terminal 1 and 2. Thicker wires may be more difficult to install.

3.4.2 The J1 relay is a “dry single pole switch”. It does not provide power by itself. Figure 11 shows how it is wired when providing a 120V output (or when output has the same voltage as the power for controller). If the load of J1 requires a different voltage than that for the controller, an additional power source will be needed (see Figure 13).

3.4.3 SSR output power does not come from the input of the SSR. The output of the SSR is a single pole switch between terminal 1 and 2 of the SSR. The input of the SSR is for control, or triggering, the SSR. (Note, we are talking about the SSR itself, not the SSR control output of the controller). Figure 12 shows how the SSR output should be wired. When switching a North American 240VAC power, the heater will be live even when the SSR is off. Users should install a double pole mechanical switch to the power input.

**4. Parameter Setting**

For safety reasons, the controller parameters are divided into three groups with different pass codes. You should only give the code to those who have the responsibility and knowledge of how to properly change it. Code 0089 contains the parameters for system configuration that may need to change during the initial set up. Code 0036 contains the parameters for tuning performance. Code 0001 is for controlling temperature and alarm settings.

**4.1 System Configuration Parameters (accessed by code 0089)**

The system configuration parameters are listed in table 1. To change the parameters, press SET key, enter code “0089” press SET key again. Then, follow the flow chart in Figure 3.

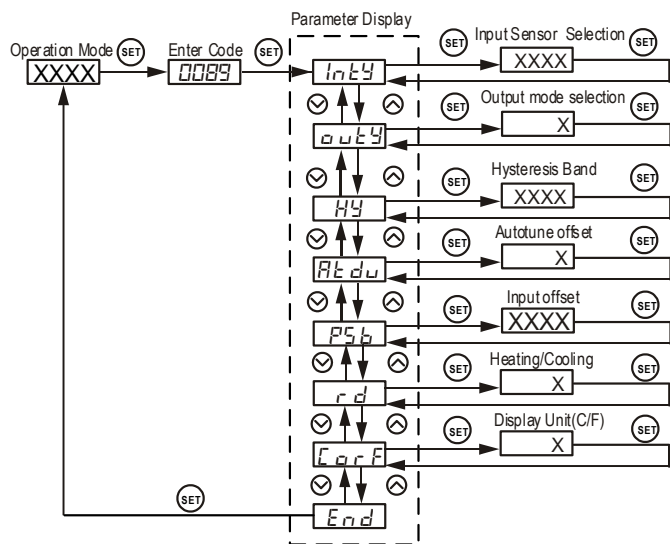

Figure 3. System setup flow chart

- (1) Press SET key to enter setting mode;
- (2) Press >, V and ^ keys to enter parameters;
- (3) Press SET key to confirm;
- (4) Press V or ^ keys to select the new parameter.

Table 1. System configuration parameters

Code	Description	Range	Initial	Note
Inty	Inty	Input Sensor Type	See table 2	1
Outy	Outy	Control Output Mode	0,1,2,3,4,5,6	2
Hy	Hy	Hysteresis Band	0~9999	3
Adtu	Adtu	Autotune Offset	0~200(deg)	4
Psb	Psb	Input Offset	-100~100(deg)	5
rd	Rd	Control Function	0: heating, 1:cooling	0
CorF	CorF	Display Unit	0: °C 1:°F	1
End	End	Exit		

**Note 1.** The controller is preset for K type thermocouple input. For any other types of sensor, the Inty value needs to be changed to the corresponding symbol as shown in Table 2.

Table 2. Temperature sensor code

Code	Description	Working Temperature Range
t	TC, Type T	-200~400°C; -320~752°F
r	TC, Type R	-50~1600°C; -58~2900°F
J	TC, Type J	-200~1200°C; -320~2200°F
WRE	TC, WRe3/25	0~2300°C; 32~4200°F
b	TC, Type B	350~1800°C; 660~3300°F
S	TC, Type S	-50~1600°C; -58~2900°F
K	TC, Type K	-200~1300°C; -320~2400°F
E	TC, Type E	-200~900°C; -320~1650°F
P10.0	RTD, Pt100	-99.9~600.0°C; -99.9~999.9°F
P100	RTD, Pt100	-200~600°C; -320~1100°F
Cu50	RTD, Cu50	-50.0~150.0°C; -60~300°F

- Note 2.** The value of outy determines the control mode. When it is set to:
- 0 - Relay J1 as alarm output; SSR output disabled.
  - 1 - Relay J1 as PID controlled relay contact output; SSR output disabled.
  - 2 - Relay J1 as alarm output; SSR PID control output.
  - 3 - Relay J1 as alarm output; SSR On/off control output.
  - 4 - J1 as On/off control relay contactor output. SSR output disabled.
  - 5 - J1 as Limit control output.
  - 6 - Relay J1 as alarm output; SSR for Limit control output.

**Note 3.** Hysteresis Band (also called dead band, or differential), Hy, is used for on/off and limit control modes. Its unit is in degrees (°C or °F). For on/off control mode, the output will be off when PV > SV and on again when PV < SV-Hy for heating. For cooling, the output will be off when PV < SV and on again when PV > SV+Hy. For limit control mode, the controller cannot be reset (to turn on the output) when PV > SV-Hy for heating, and when PV < SV+Hy for cooling.

**Note 4.** The autotune offset will shift the SV value down by the Adtu value during the auto tune process. That will prevent the system from damage due to overheating during the autotune.

**Note 5.** Calibration offset, Psb is used to set an input offset to compensate the error produced by the sensor. For example, if the meter displays 5 °C when probe is in ice/water mixture, setting Psb= -5 will make the controller display 0 °C. To set negative value, shift to the very left digit, press down key until it shows “-”.

**4.2 PID Parameters (accessed by code 0036)**

The PID parameters are listed in table 3. To change the parameters, press SET key, enter code “0036”, then press SET key again. The parameter flow chart is similar to Figure 3.

Table 3. PID and relevant parameters

Code	Description	Range	Initial	Note
P	p	Proportional Constant	0.1~99.9(%)	5.0 6
I	I	Integral Time	2~1999(Sec)	100 7
d	d	Derivative Time	0-399(Sec)	20 8
SouF	SouF	Damp Constant	0.1~1.0	0.2 9
ot	ot	Cycle Rate	2~199(Sec)	2 10
FILt	FILt	Digital Filter Strength	0~3	0 11
End	End	Exit		

The values of the P, I, and D parameters are critical for good response time, accuracy and stability of the system. Using the Auto-tune function to automatically determine these parameters is recommended for the first time user. If the auto tuning result is not satisfactory, you can manually fine-tune the PID constants for improved performance.

**Note 6.** Proportional Constant (P): P is also called the proportional band. Its unit is the percentage of the temperature range. e.g. For a K type thermocouple, the control range is 1500 °C. P=5 means the proportional band is 75 °C (1500x5%). Assuming the set temperature (SV) = 200. When integral, I, and derivative, d, actions are removed - the controller output power will change from 100% to 0% when temperature increases from 125 to 200 °C. The smaller the P value is, the stronger action will be for the same temperature difference between SV and PV.

**Note 7.** Integral time (I): Brings the system up to the set value by adding to the output that is proportional to how far the process value (PV) is from the set value (SV) and how long it has been there. When I decreases, the response speed is faster but the system is less stable. When I increases, the response speed is slower, but the system is more stable. When I=0, the integration is turned off. It becomes to a PD controller that is useful for very slow system.

**Note 8.** Derivative time (d): Responds to the rate of PV change, so that the controller can compensate in advance before |SV-PV| gets too big. A larger number increases its action. Setting d-value too small or too large would decrease system stability, causing oscillation or even non-convergence. Normally, d is set to 1/4 of the I value.

**Note 9.** Damp constant: This constant can help the PID controller further to improve the control quality. It uses artificial intelligence to dampen the temperature overshoot. When its value is too low, the system may overshoot. When its value is too high, the system will be over damped.

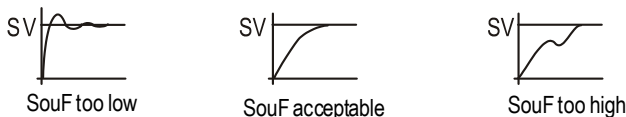

Figure 4. Damp constant

**Note 10.** Cycle rate (ot): It is the time period (in seconds) that the controller uses to calculate its output. e. g. If ot=2, and the controller output is set to 10%, the heater will be on 0.2 second and off 1.8 seconds for every 2 seconds. Smaller ot value results in more precision control. For SSR output, ot is normally set at 2. For relay or contactor output, it should be set longer to prevent contacts from wearing out too soon. It normally set to 20~30 seconds.

**Note 11.** Digital Filter (Filt): Filt=0, filter disabled; Filt=1, weak filtering effect; Filt=3, strongest filtering effect. Stronger filtering increases the stability of the readout display, but causes more delay in the response to change in temperature.

**4.3 Temperature setting and Alarm setting (accessed by code 0001)**

The temperature and alarm parameters are listed in table 4. To change the parameters, press SET key, enter code "0001", then press SET again. Figure 5 is the parameter flow chart.

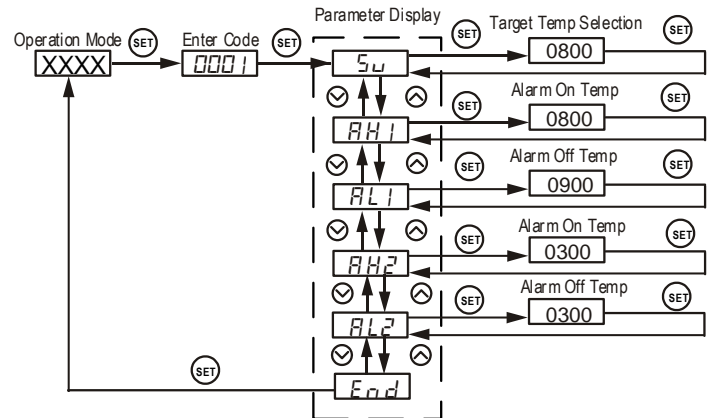

Figure 5. Flow chart for how to set target temperature and alarm

Table 4. Temperature and alarm parameters

Code	Description	Initial Setting	Note
SV	SV Target temperature (Set Value)	800	12
AH1	Alarm 1 on temperature	800	13
AL1	Alarm 1 off temperature	900	
AH2	Alarm 2 on temperature	300	
AL2	Alarm 2 off temperature	300	
End	END Exit		

**Note 12.** There are two ways to set the target temperature.

a. During the normal operation mode, press ^ or V once to switch the display from PV to SV. The display will start to blink. Press ^ or V again to increase or decrease the SV. When finished, wait 8 seconds and the setting will take effect automatically (the display will stop blinking).

b. Follow the flow chart shown in Figure 5. This method is easier for large temperature change. If no key is pressed after confirmation of SV, the controller will return to normal operation mode automatically in 1 minute.

**Note 13.** Alarm setting. When the SSR is used as the control output, the J1 relay can be used as an alarm (when outy is set to 0, 2, 3, or 6). The controller offers two alarm settings for the J1 relay. One is controlled by parameters AH1 and AL1, and the other is controlled by AH2 and AL2. AH1 and AH2 are the temperatures to turn the J1 relay on; AL1 and AL2 are the temperatures to turn the J1 relay off. When AH1(2) > AL1(2), the alarm is set for absolute high alarm as shown in Figure 6 below. When AH1 (2) < AL1(2), the alarm is set for absolute low alarm as shown in Figure 7 below. Users can press > key to temporarily turn off the alarm. The alarm will be on again if the alarm set temperature is reached again. To permanently deactivate the alarm, set AH1=AL1 or AH2=AL2.

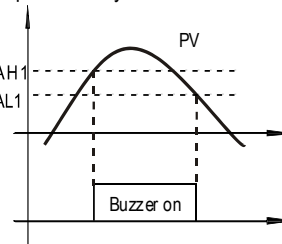

Figure 6. Absolute high alarm

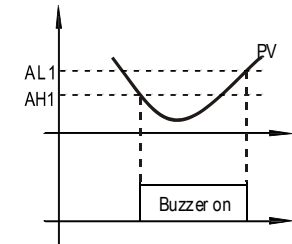

Figure 7. Absolute low alarm

**5. Auto-Tuning**

The auto-Tuning function (also called self-tuning) can automatically optimize the PID parameters for the system. The auto-tuning function will use the on/off mode to heat up the system until it passes the set point. Then let it cool down. It will repeat this about three times. Based on the response time of the system, the built-in artificial intelligence program will calculate and set the PID parameters for the controller. If your system has a very slow response, the auto tuning could take a long time.

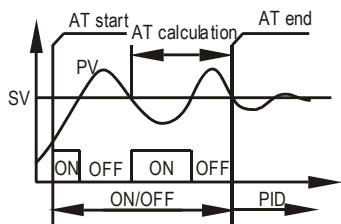

Figure 8. Auto tuning

5.1 To activate auto-tuning, press and hold > key until the “AT” indicator starts to blink, which indicates auto-tuning is in progress. When “AT” stops blinking, the auto-tuning is finished. Now, newly calculated PID parameters are set and used for the system. Please note that auto-tuning is only for PID control mode (when “outy” is set at 1 or 2).

5.2 To stop the auto-tuning, press and hold > key until “AT” indicator stops blinking. Then, the previous PID parameters values are resumed.

6. On/off control mode

On/off control mode is not as precise as PID control mode. However it is necessary for inductive loads such as motors, compressors, and solenoid valves that do not like to take pulsed power. It works like a mechanical thermostat. When the temperature passes the set point, the heater (or cooler) will be turned off. When the temperature drops back to below the hysteresis band (dead band) the heater will turn on again.

To use the on/off mode, set outy to 3 or 4 depending on the output device to be used. Then, set the Hy to the desired range based on control precision requirements. Smaller Hy value results in tighter temperature control but also causes the on/off action to occur more frequently. In the PID parameters menu (code 0036), only ot and FilT is used. P, I, D and SouF are not meaningful for the on/off control mode.

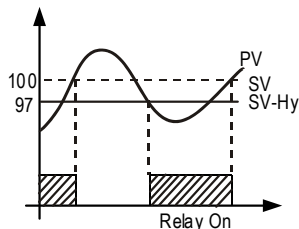

When heating, and outy=3 or 4,  
If  $PV \leq (SV - Hy)$ , relay on  
If  $PV \geq SV$ , relay off  
(SV=100, Hy=3)

Figure 9. On/off control mode

7. Limit control mode

The limit control mode will shut the heater off when SV is reached. The heater will not be turned on again until the controller is reset manually (press the SET key for 5 seconds). The controller can't be reset when the temperature is within the hysteresis band (Hy).

To use the Limit control mode, set outy to 5 or 6, and set Hy to the range that you want reset to be blocked. Power up the controller, then start the heating by pressing SET key for 5 second or until the output indicator is on.

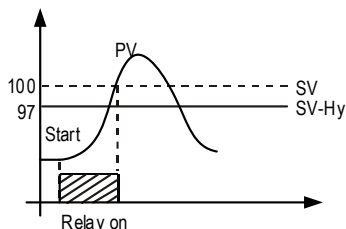

outy=5, SV=100, Hy=3. The heating stops after it reached 100 degree.

Figure 10. Limit control mode

8. Application Example

8.1 A furnace needs to be controlled at 1200 °F. The power source is 120VAC. The heating element is 1800W/120V. It is switched on/off by a contactor. The coil voltage of the contactor is 120VAC. A K type thermocouple is used as the temperature sensor.

a. Wiring diagram

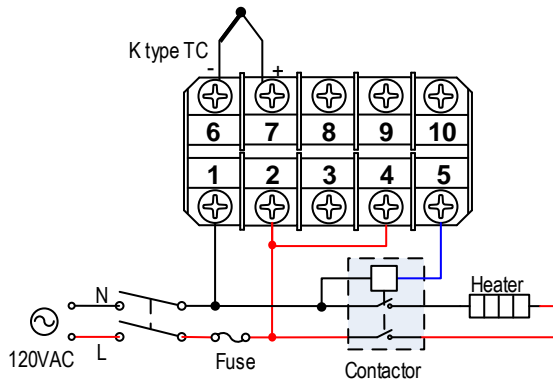

Figure 11. Typical wiring for high power and high temperature applications such as oven or kiln temperature control

b. Parameter setting. These are the parameters that need to be changed from the initial value: outy=1 for PID mode with relay output; ot=20 to increase the relay life time; SV=1200°F for the target temperature.

8.2 A water tank needs to be controlled at 200.0°F. If temperature is over 205.5 °F, the alarm will turn on to warn the operator and turn off when the temperature drops below 205.3 °F. The system consists of a 1200W 120VAC heater, a Pt100 RTD sensor, a 25A AC SSR, and a 120VAC buzzer.

a. Wiring diagram, see Figure 12.

Wiring the controller or heater with 240VAC is the same as with 120VAC

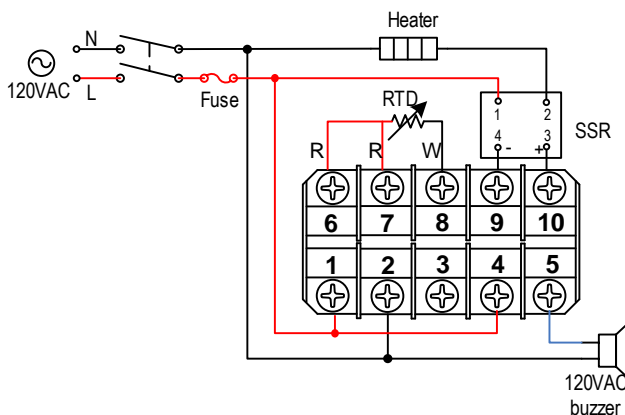

Figure 12. Typical wiring for high precision control set up. It shows how the RTD sensor and SSR should be wired.

b. Parameter setting. These are the parameters that need to be changed from the initial value: Inty=P10.0 for Pt100 RTD sensor with 0.1° resolution input, SV=200.0 °F for the target temperature. AH1=205.5 °F and AL1= 205.3 °F for the alarm.

**8.3** A furnace needs to be controlled to hold a temperature. Power source is 240VAC. Heating element is 1800W/240V. It is switched by a contactor. The coil voltage of the contactor is 24VAC. A K type thermocouple is used as the temperature sensor.

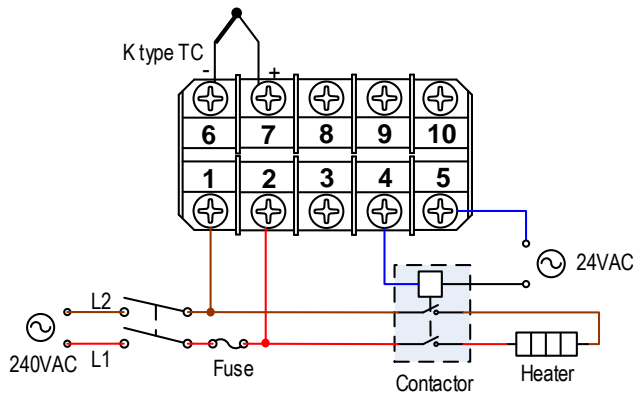

Figure 13. Wiring example for a load that requires different voltages than that for the controller power supply. This diagram also applies to a 24V solenoid valve if the contactor and heater are replaced by the valve.

**8.4 Drive a load directly**

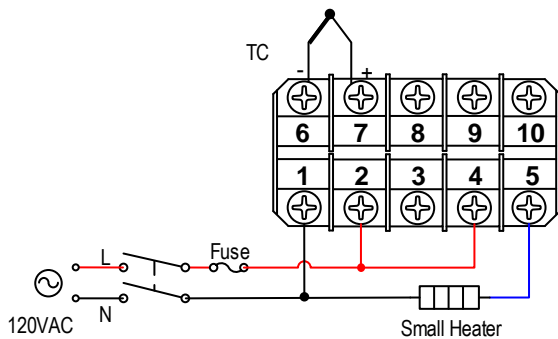

Figure 14. This is for loads that draw less than 3 Amp of current only. For parameter settings, please refer to "example 8.1".

**9. Error message and troubleshooting**

**9.1 Display EEEE**

This is an input error message. The possible reasons are, the sensor is not connected correctly; the input setting is wrong type; or the sensor is defective. If this happens when using thermocouple sensor, you can short terminal 6 and 7. If the display shows the ambient temperature, the thermocouple is defective. If it still displays EEEE, check the input setting, Inty, to make sure it is set to the right thermocouple type. If Inty setting is correct, the controller is defective. For RTD sensor, check the input setting first because most controllers are shipped with input set for thermocouple. Then check the wiring. The two red wires should be on terminal 6 and 7. The clear/white wire should be on terminal 8.

**9.2 No heating**

When controller output is set for relay output, the "AL" LED is synchronized with output relay. When controller output is set for SSR output, the "OUT" LED is synchronized with SSR control output. If there is no heat when it is supposed to, check the AL or OUT first. If it is not lit, the controller parameter setting is wrong. If it is on, check external switching device (if the relay is pulled-in, or the red LED of the SSR). If the external switching device is on, then the problem is either the external switching device output, its wiring, or the heater. If the external switching device is not on, then the problem is either the controller output, or the external switch device.

**9.3 Poor Accuracy**

Please make sure calibration is done by immersing the probe in liquid. Comparing with reference in air is not recommended because response time of sensor depends on its mass. Some of our sensor has response time >10 minutes in the air. When the error is larger than 5°F, the most common problem is improper connection between the thermocouple and the controller. The thermocouple needs to be connected directly to the controller unless a thermocouple connector or an extension wire is used. A copper connector, copper wire, or thermocouple extension wire with wrong polarity connected on the thermocouple will cause the reading drift more than 5°F.

**Auber Instruments Inc.**

5755 North Point Parkway, Suite 99,  
 Alpharetta, GA 30022  
[www.auberins.com](http://www.auberins.com)  
 Email: [info@auberins.com](mailto:info@auberins.com)  
 Tel: 770-569-8420

Copyright 2007-2015, Auber Instruments All Rights Reserved.  
 No part of this manual shall be copied, reproduced, or transmitted in any way without the prior, written consent of Auber Instruments. Auber Instruments retains the exclusive rights to all information included in this document.