

Quick Guide for Charcoal Smoker Temperature Controller Ver 1.1

This temperature controller is for Charcoal Smoker. To operate it, connect the 12VDC power adapter to the terminal 1 and wall outlet. Connect the fan connector to terminal 2. The polarity for this socket is center pin positive (+), outer collar negative (-). Connect the K thermocouple to the terminal 3. **Please note that thermocouple connector also has polarity. The wide blade should go to wide slot.**

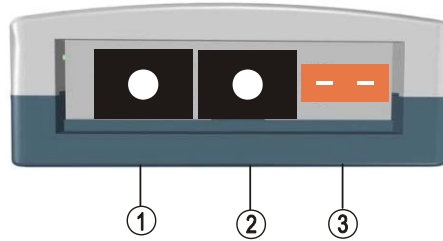

- ① POWER-12V Power supply input
- ② OUT- Fan control output
- ③ INPUT-Temperature probe input

Figure 1. Controller connector identification.

Application tips.

- 1) The PID parameters are optimized for Charcoal smoker. Users don't need to change them. If you need further information about how to fine tune the controller, please refer to the instruction manual.
- 2) The thermocouple cable is food grade, which is insulated by TEFLON (PFA) with stainless steel over braid. The maximum working temperature for the cable is 500°F. Please do not drop the cable on top of the flame or drape it over the fire box.
- 3) To set target temperature:
There are two ways to set the target temperature.
 - a. During the normal operation mode, press \wedge or \vee once to switch the display from process value (PV) to set value (SV, or target temperature). The display will start to blink. Press \wedge or \vee again to increase or decrease the SV. When finished, wait 8 seconds and the setting will take effect automatically (the display will stop blinking).
 - b. Press SET key once. Use $>$, \wedge and \vee keys to enter code 0001. Press SET key to confirm, then the display would be SV (Su). Press SET key again to display the SV setting. Use $>$, \wedge and \vee keys to enter the new SV and press SET to confirm. Press \vee key to change the display to END. Then, press SET to exit. You can also ignore the steps after confirmation of SV. The controller will return to normal operation mode if no key is pressed for 1 minute. Figure 2 is a detailed flow chart that shows how to set the SV.
- 4) To set alarm:
The controller offers two alarms that can be set to turn on the buzzer at specific temperatures. The first alarm is controlled by parameter AH1 and AL1. The initial setting will turn on the buzzer at 250°F and off when temperature drops below 249°F. The second alarm is controlled by parameter AH2 and AL2. The initial setting of the second alarm is deactivated. It can be set as low alarm to send warning when charcoal is low.
AH1 and AH2 are the temperature to turn buzzer on; AL1 and AL2 are the temperature to turn buzzer off. When AH1(2) >AL1(2), the alarm is set for absolute high alarm, When AH1(2)

<AL1(2), the alarm is set for absolute low alarm, When AH1(2)=AL1(2), the alarm is deactivated.

For example, if AH1=250, AL1=249, when the temperature goes up to 250°F, the buzzer will be on; when the temperature drops down to 249°F, the buzzer will be off.

If AH2=180, AL2=185, when the temperature drops down to 180°F, the buzzer will be on; when the temperature goes up to 185°F, the buzzer will be off.

User can press the shift key (>) to temporarily silence the buzzer sound alarm. The alarm will buzz again if the alarm set temperature is reached again. To permanently deactivate the alarm, set AH1=AL1 or AH2=AL2. Please see flow chart below on how to set the value.

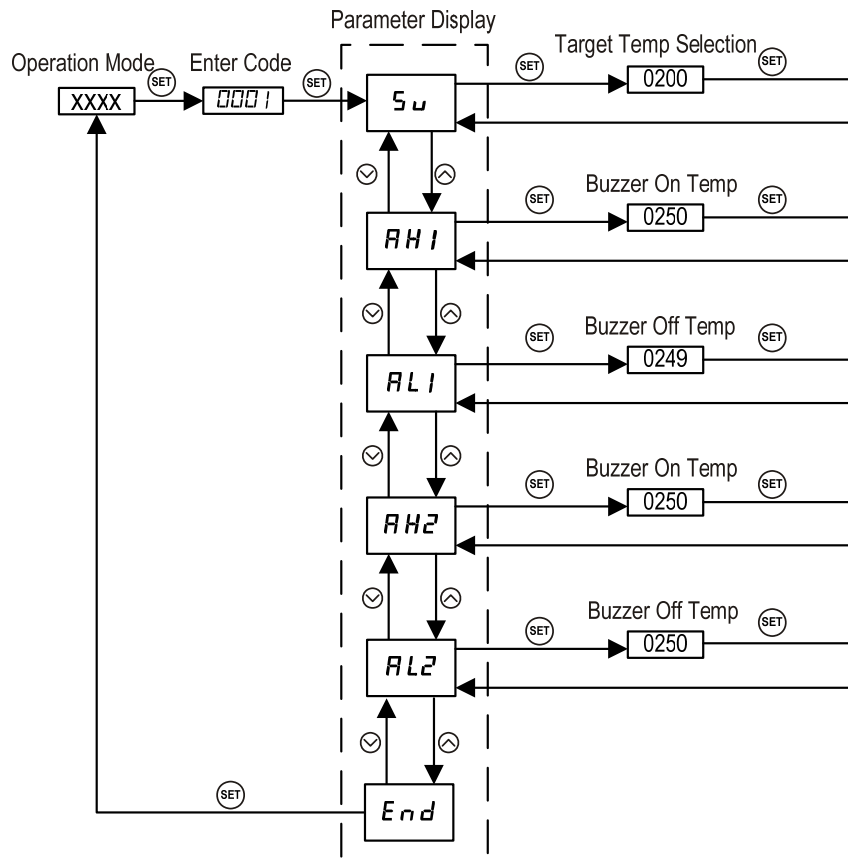

Figure 2. Flow charge of how to set the target temperature (SV) and alarms.