

Instruction Manual

SYL-2342H HUMIDITY CONTROLLER INSTRUCTION MANUAL

Version 1.2

Caution

- This controller is intended to control equipment under normal operating conditions. If failure or malfunction of the controller may lead to abnormal operating conditions that may result in personal injury or damage to the equipment or other property, devices (limit or safety controls) or systems (alarm or supervisory) intended to warn of or protect against failure or malfunction of the controller must be incorporated into and maintained as part of the control system.
- Installing the rubber gasket supplied will protect the controller front panel from dust and water splash (IP54 rating). Additional protection is needed for higher IP rating.
- This controller carries a 90-day warranty. This warranty is limited to the controller only.

1. Specification

Accuracy	3%
Control mode	On-off control
Output mode	Relay contact (NO): 250VAC/7A, 120V/10A, 24VDC/10A
Alarm output	Relay contact. 250VAC/1A, 120VAC/3A, 24V/3A
Alarm function	Process high alarm, process low alarm, deviation high alarm, and deviation low alarm
Power supply	85~260VAC/50~60Hz
Power consumption	≤5 Watt
Ambient temperature	0~50°C, 32~122°F
Dimension	48 x 48 x 100 mm (WxHxD)
Mounting cutout	45 x 45 mm

2. Terminal Wiring

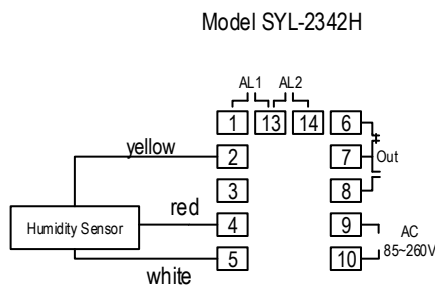

Figure 1. Wiring diagram

3.1 Sensor connection

Signal wire (yellow) should be connected to terminal 2. Voltage supply (red) should be connected to terminal 4. Ground wire (white) should be connected to terminal 5.

3.2 Power to the controller

The power cables should be connected to terminals 9 and 10. Polarity does not matter. It can be powered by 85-260V AC power source. Neither a transformer nor jumper is needed to wire it up. For the sake of consistency with the wiring example described later, we suggest you connect the hot wire to terminal 9 and neutral to 10.

3.3 Control output connection

The relay output of the controller can be used to turn on a contactor or a solenoid valve. It can drive a small Humidifier directly if it draws less than 10 Ampere when connected to 120V AC power source. For applications needing two control outputs, such as one for humidifying and another for dehumidifying, relays AL1 or AL2 can be used for the second output with on/off control mode. Please see Figure 5 for details.

3.3.1 Connecting the load through a contactor

Assuming the controller is powered by 120V AC and the contactor has a 120V AC coil, jump a wire between terminals 8 and 9. Connect terminal 7 to one lead of the coil and terminal 10 to the other lead of the coil. Please see Figure 6 for example.

3.3.2. Connecting the humidifier directly from the internal relay

Assuming the controller and the load are powered by the same voltage. Jump a wire from terminal 9 to 8. Connect terminal 7 to the one lead of the load and terminal 10 to the other lead of the load. Please see Figure 5 for details.

3.4 For first time users without prior experience with PID controllers, the following notes may prevent you from making common mistakes.

3.4.1 Power to the humidifier/dehumidifier does not flow through terminal 9 and 10 of the controller. The controller consumes less than 2 watts of power. It only provides a control signal to the relay. Therefore, wires in the 18 to 26 gauge range should be used for providing power to terminals 9 and 10. Thicker wires may be more difficult to install.

3.4.2 The control relay outputs, -AL1 and AL2, are “dry” single pole switches. They do not provide power by themselves. Please see Figure 5 and 6 for how they are wired when providing a 120V output (or when output voltage is the same as the power source for the controller).

4. Front Panel and Operation

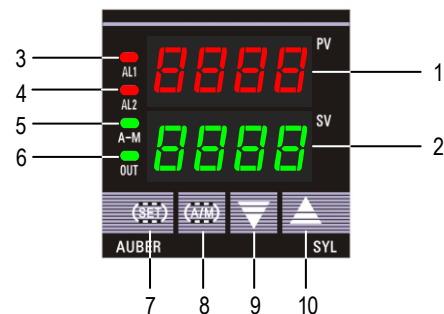

Figure 2. Front panel

- ① PV display: Indicates the sensor read out, or process value (PV).
- ② SV display: Indicates the set value (SV).
- ③ AL1 indicator: It lights up when AL1 relay is on.
- ④ AL2 indicator: It lights up when AL2 relay is on.
- ⑤ A-M indicator: This indicator is not used in On/off control mode
- ⑥ Output indicator: It is synchronized with control output (terminal 7 and 8), and the power to the load. When it is on, the humidifier (or dehumidifier) is powered.
- ⑦ SET key: When it is pressed momentarily, the controller will switch the lower (SV) display between set value and percentage of output (this is only useful in PID or manual control mode). When pressed and held for two seconds will put the controller into parameter setting mode.
- ⑧ Data shift key: Decimal point position can be shifted by pressing A/M key
- ⑨ Decrement key ▼: Decreases numeric value of the setting value.
- ⑩ Increment key ▲: Increases numeric value of the setting value.

4.2 Basic Operation

4.2.1 Changing set value (SV)

Press the ▼ or ▲ key once, and then release it. The decimal point on the lower right corner will start to flash. Press the ▼ or ▲ key to change SV until the desired value is displayed. If the change of SV is large, press the A/M key to move the flashing decimal point to the desired digit that needs to be changed. Then press the ▼ or ▲ key to start changing SV from that digit. The decimal point will stop flashing after no key is pressed for 3 seconds. The changed SV will be automatically registered without pressing the SET key.

4.2.2 Parameter Setup Mode

When the display mode is 1 or 2, press SET and hold for roughly 2 seconds until the parameter setup menu is displayed. Please refer to 4.3 for how to set the parameters.

4.3 Setup flow chart

While in the parameter setup mode, use ▲ and ▼ to modify a digit and use A/M to select the digit that needs to be modified. Press the A/M and SET key at the same time to exit the parameter setup mode. The instrument will automatically exit if no key is pressed for 10 seconds. Figure 3 is the setup flow chart.

Please note the changed parameter will be automatically registered without pressing the SET key.

4.4 Parameter Setting

Table 2. System parameters

Code	Description	Setting Range (RH %)	Initial Setting	Remarks
ALM1	Process high alarm	0~100	100	See 4.4.1
ALM2	Process low alarm	0~100	50	
Hy-1	Deviation high alarm	0~100	9999	
Hy-2	Deviation low alarm	0~100	9999	
Hy	Hysteresis Band	0~100	0.3	See 4.4.2
Pb	Input offset	0~100	0.0	See 4.5
AL-P	Alarm output definition	0-31	17	See 4.6
COOL	System function selection	0 or 1	0	See 4.7
Lock	Configuration privilege	0~99999	0	See 4.8

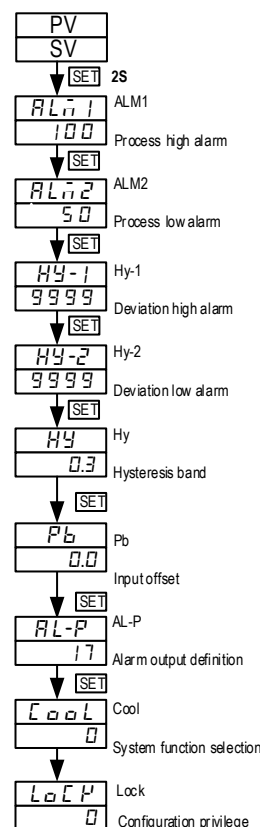

Figure 3. System setup flow chart

4.4.1 Alarm parameters

This controller offers four types of alarm, “ALM1”, “ALM2”, “Hy-1”, “Hy-2”.

- ALM1: High limit absolute alarm. If the process value is greater than the value specified as “ALM1+Hy” (Hy is the Hysteresis Band), then the alarm will turn on. It will turn off when the process value is less than “ALM1-Hy”.
- ALM2: Low limit absolute alarm. If the process value is less than the value specified as “ALM2-Hy”, then the alarm will turn on, and the alarm will turn off if the process value is greater than “ALM2+Hy”.
- Hy-1: Deviation high alarm. If the humidity is above “SV+Hy-1 +Hy”, the alarm will turn on, and the alarm will turn off if the process value is less than “SV+Hy-1 -Hy” (we will discuss the role of Hy in the next section)
- Hy-2: Deviation low alarm. If the humidity is below “SV-Hy-2 -Hy”, the alarm will turn on, and the alarm will turn off if the humidity is greater than “SV-Hy-2 +Hy”.

The things you should know about alarm

1) Absolute alarm and deviation alarm

High (or low) limit absolute alarm is set by the specific humidity that the alarm will be on. Deviation high (or low) alarm is set by how many percent above (or below) the control target humidity (SV) that the alarm will be on.

e.g. Assuming ALM1=80, Hy-1=2, SV=50. When the humidity (PV) is above 52, the deviation alarm will be on. When the humidity is above 80, the process high alarm will be on. Later, when SV changes to 40, the deviation alarm will be changed to 42 but process high alarm will remain the same. Here the Hysteresis Band (Hy) setting is ignored. Please see 4.4.2 for details.

2) Assignment of the relays for the alarms

AL1 and AL2 are the name of the two relays used for alarm output. AL1 is the alarm relay 1 and AL2 is alarm relay 2. Please do not confuse the relays with alarm parameter ALM1 (process high alarm) and ALM2 (process low alarm). Either the AL1 or the AL2 can be used for any of the four alarms. AL-P (alarm output definition) is a parameter that allows you to select the relay(s) to be activated when the alarm set condition is met. You can set all four alarms to activate the one relay (AL1 or AL2), but you can't activate both relays for with just one alarm.

3) Display of the alarm

When AL1 or AL2 relay is activated, the LED on the upper left will light up. If you have multiple alarms assigned to a single relay, you might want to know which alarm activated the relay. This can be done by setting the E constant in the AL-P parameter (see 4.6). When E=0, the bottom display of the controller will alternately display the SV and the activated alarm parameter.

4.4.2 Hysteresis Band "Hy"

The Hysteresis Band parameter Hy is also referred as Dead Band, or Differential. It permits protection of the on/off control from high switching frequency caused by process input fluctuation. Hysteresis Band parameter is used for on/off control, 4-alarm control. For example: 1) When controller is set for on/off humidifying control mode, the output will turn off when humidity goes above SV+Hy and on again when it drops to below SV-Hy. 2) If the high alarm is set at 60 and hysteresis is set for 2, the high alarm will be on at 62 (ALM1+Hy) and off at 58 (ALM1-Hy).

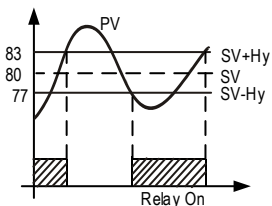

When humidifying,
If $PV \leq (SV - Hy)$, relay on
If $PV \geq (SV + Hy)$, relay off
(SV=80, Hy=3)

Figure 4. On/off control mode

4.5 Input offset "Pb"

Pb is used for calibrating sensor. The initial value is set of the particular sensor shipped with controller.

4.6 Alarm output definition "AL-P"

Parameter "AL-P" may be configured in the range of 0 to 31. It is used to define which alarms ("ALM1", "ALM2", "Hy-1" and "Hy-2") is output to AL1 or AL2. Its function is determined by the following formula:

$$AL-P = AX1 + BX2 + CX4 + DX8 + EX16$$

- If A=0, then AL2 is activated when Process high alarm occurs;
- If A=1, then AL1 is activated when Process high alarm occurs;
- If B=0, then AL2 is activated when Process low alarm occurs;
- If B=1, then AL1 is activated when Process low alarm occurs;
- If C=0, then AL2 is activated when Deviation high alarm occurs;
- If C=1, then AL1 is activated when Deviation high alarm occurs;
- If D=0, then AL2 is activated when Deviation low alarm occurs;
- If D=1, then AL1 is activated when Deviation low alarm occurs;
- If E=0, then alarm types, such as "ALM1" and "ALM2" will be displayed alternately in the lower display window when the alarms are on. This makes it easier to determine which alarms are on.
- If E=1, the alarm will not be displayed in the lower display window (except for "orAL"). Generally this setting is used when the alarm output is used for control purposes.

For example, in order to activate AL1 when a Process high alarm occurs, trigger AL2 by a Process low alarm, Deviation high alarm, or Deviation low alarm, and not show the alarm type in the lower display window, set A=1, B=0, C=0, D=0, and E=1. Parameter "AL-P" should be configured to: AL-P=1X1+0X2+0X4+0X8+1X16=17 (**this is the factory default setting**)

Note: Unlike controllers that can be set to only one alarm type (either absolute or deviation but not both at same time), this controller allows both alarm types to function simultaneously. If you only want one alarm type to function, set the other alarm type parameters to maximum or minimum (ALM1, Hy-1 and Hy-2 to 100, ALM2 to 100) to stop its function.

4.7 "COOL" for Humidifying and Dehumidifying Selection

Parameter "COOL" is used to set humidifying or dehumidifying function. When COOL=1, Dehumidifying control. The output relay turns on when humidity is higher than set point (SV) When COOL=0, Humidifying control. The output relay turns on when humidity is below the set point (SV).

4.8 Configuration Privilege "Lock"

This controls which parameters can be viewed or changed by user. The default setting (0) allows all 8 parameters for humidity control to be viewed and changed. If you want to reduce the number of parameters accessible, or want to activate the PID control mode, please refer to SYL-2352 instruction manual or contact factory.

5. Wiring examples

5.1 Controlling the load directly with internal relay

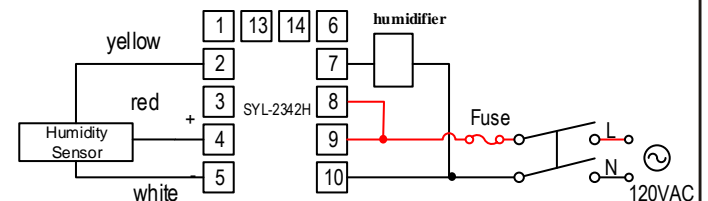

Figure 5. SYL-2342H control the humidifier directly by the internal relay of the controller. The humidifier must consume less current than the internal relay's maximum rating (7A at 240VAC and 10A at 120VAC).

5.2 Controlling the load via external contactor

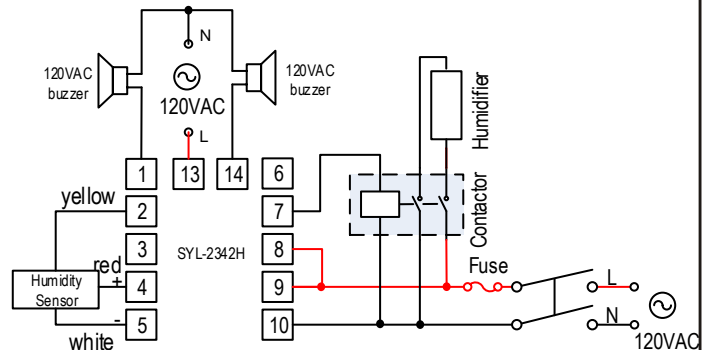

Figure 6. SYL-2342H with external relay output.

Using the external contactor allows users to control higher power loads than the internal relay can handle. It is also easy to service. If the contacts of the relay wear out, it is more economical to replace them than to repair the controller. In this example, we assume the coil voltage of the contactor is the same as the voltage of the controller power supply. The voltage of power supply for alarm is 120V AC. **Note: You don't have to wire or set the alarm to control the humidity. It is just to show how the alarm can be wired.**

Quick Guide for SYL-2342H

1. Wiring

- 1) Power to the controller. Connect the 85-260V AC power to terminals 9 and 10.
- 2) Control output connection. Connect terminals 7 and 8 for output.
- 3) Sensor connection. connect the positive wire (red) to terminal 4, the negative(white) to terminal 5. Sensor input (yellow) to terminal 2.

2. Setting the controller for humidifying/dehumidifying control.

For humidifying control, set COOL=0; For dehumidifying control, set COOL=1

3. Setting target humidity (SV)

Press the ▼ or ▲ key once, and then release it. The decimal point on the lower right corner will start to flash. Press the ▼ or ▲ key to change SV until the desired value is displayed. The decimal point will stop flashing after no key is pressed for 3 seconds. You can press the A/M key to move the flashing decimal point to the desired digit that needs to change. Then press the ▼ or ▲ key to change SV starting from that digit.

8. Error Message and trouble shooting

8.1 No humidifying

When the controller output is set for relay output, the "O U T" LED is synchronized with output relay. If humidifier has no output when it is supposed to, check the OUT LED first. If it is not lit, the controller parameter settings are wrong. If it is on, check the external switching device (if the relay is pulled-in). If the external switching device is on, then the problem is either the external switching device output, its wiring, or the humidifier

Auber Instruments

5755 North Point Parkway, Suite 99

Alpharetta, GA 30022

www.auberins.com

e-mail: info@auberins.com Tel: 770-569-8420

Copyright 2007-2015, Auber Instruments All Rights Reserved.
No part of this manual shall be copied, reproduced, or transmitted in any way without the prior, written consent of Auber Instruments. Auber Instruments retains the exclusive rights to all information included in this document.