

Instruction Manual

SYL-2802 Dual-Channel Temperature Meter for Brew Panel

Version 1.0 (August, 2016)

⚠ Caution

- This temperature meter is intended to control equipment under normal operating conditions. Failure or malfunction of the temperature meter may lead to abnormal operating conditions that may result in personal injury or damage to the equipment or other property. Devices (limit or safety controls) or systems (alarm or supervisory) intended to warn of or protect against failure or malfunction of the temperature meter must be incorporated into and maintained as part of the control system.
- Installing the rubber gasket supplied will protect the temperature meter from dust and water splash (IP54 rating). Additional protection is needed for higher IP rating.
- This temperature meter carries a 90-day warranty. This warranty is limited to the temperature meter only.

1. Specifications

Input type	RTD (Resistance Temperature Detector): Pt100
Input range	-328 ~ 1112°F (-200 ~ +600°C)
Accuracy	±0.2% or ±1 unit of full input range
Display resolution	1°C, 1°F
Alarm output	Relay AL1 (1 x N.O. and 1 x N.C.): 7 A at 240Vac, 10 A at 120 Vac, or 10 A at 24 Vdc Relay AL2 (1 x N.O.): 3 A at 240 Vac
Alarm function	Process high and low alarms, latched or pulsed action
Power supply	85 ~ 260 Vac, 50 ~ 60 Hz
Power consumption	≤ 2 Watt
Ambient temperature	0 ~ 50°C, 32 ~ 122°F
Dimension	48 x 48 x 100 mm (W x H x D)
Mounting cutout	45 x 45 mm

2. Terminal Assignments

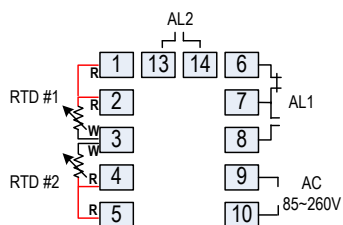

Figure 1. Wiring terminals of SYL-2802.

2.1 Sensor connection

This temperature meter SYL-2802 only accepts Pt100 RTD sensors. There are two input channels. Terminal 1, 2, and 3 are for Channel 1 (Probe 1); terminal 3, 4, and 5 are for Channel 2 (Probe 2). For a three-wire RTD with standard DIN color code, the two red wires should be connected to the terminal 1 and 2 for Probe 1 (terminal 4 and 5 for Probe 2). The white wire should be connected to terminal 3 for Probe 1 (terminal 3 for Probe 2 as well). For a two-wire RTD,

the wires should be connected to terminal 2 and 3 for Probe 1 (terminal 3 and 4 for Probe 2). Jump a wire between terminal 1 and 2 for Probe 1 (terminal 4 and 5 for Probe 2).

2.2 Power input

The power cables should be connected to terminal 9 and 10. Polarity does not matter. It can be powered by 85 ~ 260 Vac power source. Neither a transformer nor jumper is needed to wire it up. For the sake of consistency with the wiring example described later, we suggest you connect the hot wire to terminal 9 and neutral to 10.

2.3 Output connection

There are two output relays on this temperature meter, relay AL1 is associated with Channel 1 and relay AL2 is associated with Channel 2. Relay 1 (AL1) is a C-form relay with one pair of normally open contacts (terminal 7 and 8) and one pair of normally close contacts (terminal 7 and 6). Relay 2 (AL2) is a normally open relay (terminal 13 and 14).

These relays can be used to turn on a contactor or a solenoid valve. They can also drive small heaters directly if the heater draws less than 10A at 120Vac power.

2.4 For first time users without prior experience with this temperature meter, the following notes may prevent you from making common mistakes

2.4.1 Power to the load does not flow through this temperature meter to relay AL1 or AL2. The temperature meter itself consumes less than 2 watts of power. It only provides a control signal to the relay. Therefore, wires in the range from 18 to 26 gauge should be used for providing power to terminal 9 and 10. Using thicker wires on terminal 9 and 10 is unnecessary and it may become difficult to install the wires.

2.4.2 The output relays, AL1 and AL2, can be considered as “dry” single-pole switches. They do not provide power to loads. Please see Figure 5 for how they are wired when providing a 120V output (or when output voltage is the same as the power source for the temperature meter). If the load requires a different voltage than what is supplied to the temperature meter, then another power source is needed. See Figure 6 for examples.

3. Front Panel and Operation

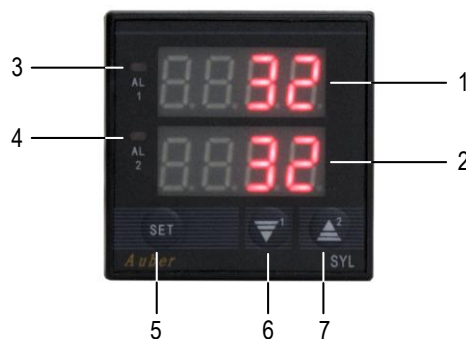

Figure 2. Front panel

- ① PV1 display: shows temperature readout from probe 1 (RTD #1).
- ② PV2 display: shows temperature readout from probe 2 (RTD #2).
- ③ AL1 indicator: it lights up when AL1 relay is engaged.

- ④ AL2 indicator: it lights up when AL2 relay is engaged.
- ⑤ SET key: In normal operating mode, press and hold it for two seconds to enter the parameter setting mode. In parameter setting mode, press it to confirm the change of a value and go to the next parameter.
- ⑥ DOWN key/Function Key 1 (▼¹): in parameter setting mode, pressing it can reduce the numeric value of a parameter, or scroll down a list. In normal operating mode, pressing it can mute/cancel Relay 1 (AL1). Please check section 4.3.
- ⑦ UP key/Function Key 2 (▲²): in parameter setting mode, pressing it can increase the numeric value of a parameter, or scroll up a list. In normal operating mode, pressing it can mute/ cancel Relay 2 (AL2). Please check section 4.3.

3.1 Display Modes

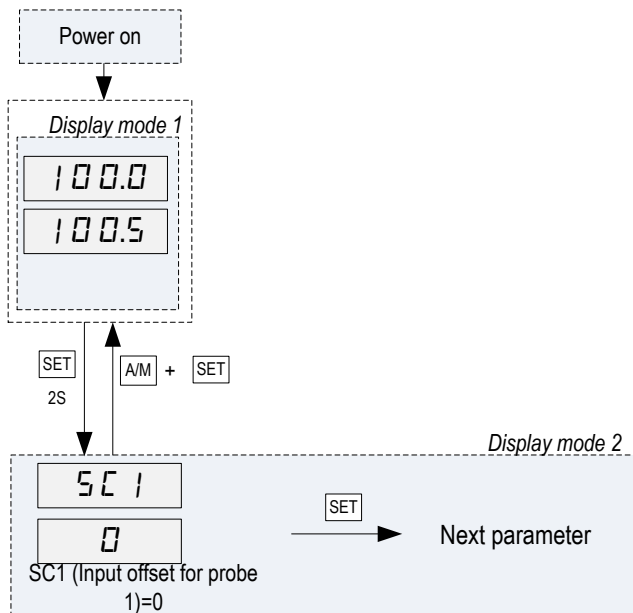

Figure 3. Display modes

Display mode 1: normal operating mode. When SYL-2802 is powered on, the upper display window shows the sensor readout from probe 1 and the lower window shows the sensor readout from probe 2.

Display mode 2: parameter setting mode. Press the SET key for 2 seconds to enter parameter setting mode. This mode allows users to change system parameters.

3.2 Switching between two display modes

When the gauge is in **normal operating mode**, press SET key and hold it for 2 seconds till the first parameter "SC1" is shown in the top display, now the gauge is in parameter setting mode. To return back to normal operating mode, leave the key pad untouched for 10 seconds.

3.3 Flow chart of accessing system parameters

When the gauge is in the parameter setting mode, the top display shows the name of a parameter, the bottom shows the value of the parameter. Use ▲ and ▼ key to modify the value; then press SET key will confirm the change and go to the next parameter.

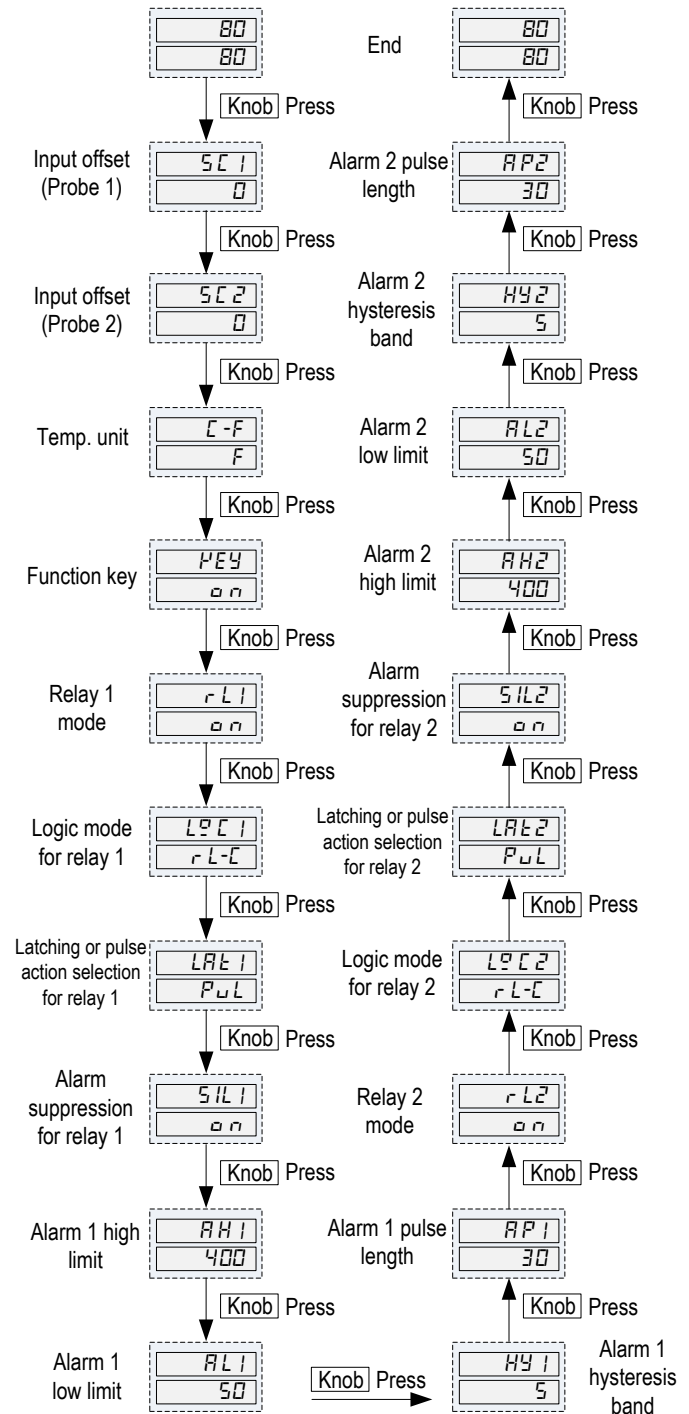

Figure 4. Flow chart of accessing system parameters.

4. System Parameters

Table 1. List of system parameters.

Code	Description	Setting Range	Initial Setting	Remarks
SC1	Input offset of Probe 1	-99 ~ +99°C or °F	0	See 4.1
SC2	Input offset of Probe 2	-99 ~ +99°C or °F	0	
C-F	Temp. unit	°C, °F	°F	See 4.2
KEY	Function key	On, Off	On	See 4.3
RL1	Relay 1 mode	On, Off	On	See 4.4
Lgc1	Logic mode of Relay 1	RL-C, RL-O	RL-C	See 4.5
LA1	Latching or pulsing action of Relay 1	N, Y, PUL	PUL	See 4.6
SiL1	Alarm suppression of Relay 1	On, Off	ON	See 4.7
AH1	Alarm 1 high limit	OFF, -39 ~ 999	400	See 4.8
AL1	Alarm 1 low limit	OFF, -39 ~ 999	50	See 4.9
HY1	Alarm 1 hysteresis band	0.1-100.0	5	See 4.10
AP1	Alarm 1 pulse length	1-100	30	See 4.11
RL2	Relay 2 mode	On, Off	On	See 4.4
Lgc2	Logic mode of relay 2	RL-C, RL-O	RL-C	See 4.5
LA2	Latching or pulsing action of relay 2	N, Y, PUL	PUL	See 4.6
SiL2	Alarm suppression of relay 2	On, Off	ON	See 4.7
AH2	Alarm 2 high limit	OFF, -39 ~ 999	400	See 4.8
AL2	Alarm 2 low limit	OFF, -39 ~ 999	50	See 4.9
HY2	Alarm 2 hysteresis band	0.1-100.0	5	See 4.10
AP2	Alarm 2 pulse length	1-100	30	See 4.11

4.1 SC (Input Offset)

SC is used to set an input offset to compensate the error produced by the sensor or input signal itself. SC1 is for Probe 1 and SC2 is for Probe 2. For example, if Probe 1 reading of a properly prepared ice bath is 33°F, setting SC1 = -1, will correct the Probe 1 reading to 32°F.

4.2 C-F (Temperature Unit)

C-F determines the temperature unit. It can be set to C (Celsius, °C) or F (Fahrenheit, °F).

4.3 KEY (Function Key)

The setting of KEY determines whether to enable the Function Key 1 (share with ▼¹ key) and Function Key 2 (shared with ▲² key). By default, Function Keys are disabled (KEY = off). To enable these two keys, set the parameter "KEY" to "on" (Key = on). When enabled, pressing Function Key 1 can reset/cancel the action of Relay 1 (AL1); pressing Function Key 2 can reset/cancel the action of Relay 2 (AL2). Function Keys only work in Latching Mode or Non-Latching Mode (LA1 = Y or N); they have no effects in Pulsing Mode (LA1 = PuL).

For a relay whose logic mode is set to Logic Close (Lgc = RL-C), press the function key when the relay is activated will cancel the relay action. For a relay whose logic mode is set to Logic Open (Lgc = RL-O), press the function key when the relay is activated will cancel the relay action.

4.4 RL (Relay Mode)

The setting of RL determines whether to enable the relay output. RL1 is for Relay AL1 and RL2 is for Relay AL2. When RL is set to "on", the corresponding relay

will work in synchronization with process temperature alarms. The relay can either be triggered by a process high alarm, by a process low alarm, or by both.

4.5 Lgc (Relay Logic Mode)

Parameter Lgc determines relay status before and after the alarm conditions are met. It can be set to Logic Close (RL-C) or Logic Open (RL-O).

For a NO relay, if its relay logic is set to RL-C, it stays open when it is inactive; the relay contacts close (pull-in) when alarm conditions are met. For a NO relay, if its relay logic is set to RL-O, the relay is essentially a NC relay, it stays closed when it is inactive; the relay contacts open up (drop-out) when alarm conditions are met.

Similarly, for a NC relay, if its relay logic is set to RL-C, it stays closed when it is inactive; the relay contacts open up when alarm conditions are met. If its relay logic is set to RL-O, the relay is essentially a NO relay, it stays open when it is inactive; the relay contacts close when alarm conditions are met.

For most applications, the relay should be set to Logic Close (RL-C), which is the default setting. The Logic Open (RL-O) configuration is useful if user want to turn on a device when the temperature is not in the alarm zone.

4.6 LA1 (Latching, Pulsing, or Non-Latching Relay Action)

Parameter LA1 determines the relay actions when alarm conditions are met and/or then removed. It can be set to Y for Latching Mode, PUL for pulsing mode, or N for Normal Mode.

When LA1 is set to Y (Latching Mode), the relay action is latched. It will not release even if the alarm condition is removed. To release the relay, user must reboot the temperature meter or use the function Key to cancel the relay action (see section 4.3).

When LA1 is set to PUL (Pulsing Mode), the relay action is a timed single pulse. When the alarm condition is met, relay will be activated only for a pre-determined period of time. User can set the pulse duration by the parameter AP, whose value ranges from 1 to 100 seconds. This feature is useful in situations where a user only need to ring a buzzer for a short time or want to drive an external load for a fixed time duration.

When LA1 is set to N (Non-Latching), the relay action will follow the alarm condition. The relay stops its action when the alarm condition is removed.

4.7 SiL (Relay Silence, Alarm Suppression)

Parameter SiL determines whether a relay action should be suppressed when this temperature meter is just powered up. When SiL is set to Y, Relay Silence is enabled; when SiL is set to N, Relay Silence is disabled. This function only works for process low alarm. This feature is useful when you power up the temperature meter while the temperature reading is in the alarm zone but you don't want the relay to pull.

Relay Silence/Alarm Suppression is only supposed to work when: 1) the temperature meter is just powered up, and 2) The readout temperature is below AL + Hy. Once the temperature reaches AL + Hy, the Alarm Suppression is deactivated.

For example, on a temperature meter AH1 = 200, AL1 = 100, HY1 = 1, RL1 = On, Lgc1 = RL-C, LA1 = N, SiL1 = On. When the temperature meter is just powered up, it reads 76°F. But Relay 1 (AL1) will not pull in due to Alarm Suppression. When Probe 1 reading reaches 101°F or higher (i.e., AL1 + HY1

= 100 + 1 = 101), the Alarm Suppression is deactivated. And if later on Probe 1 reading drops below 100°F, relay 1 will pull in.

4.8 AH (High Alarm)

Parameter **AH** determines at what temperature that is higher than the set temperature the alarm relay will be activated. The unit is in degree °C or °F. **AH1** is for Relay 1 and **AH2** for Relay 2. It can be set to any temperature that the temperature meter is capable of reading, or set to "off". If a relay is enabled (**RL1 = On** or **RL2 = On**), the value of **AH** represents the absolute high alarm; the relay will be activated when **PV >= AH**.

4.9 AL (Low Alarm)

It determines at what temperature that is lower than the set temperature the alarm relay will be activated. The unit is in degree °C or °F. It can be set to any temperature that the temperature meter is capable of reading, or set to "off". If a relay is enabled (**RL1 = On** or **RL2 = On**), the value of **AL** represents the absolute low alarm; the relay will be activated when **PV <= AL**.

Tip 1: **AL** should always be less than **AH** (**AL1 < AH1, AL2 < AH2**), otherwise, the alarm relay will stay activated all the time.

Tip 2: A relay can be set to work for process high alarm only (i.e., set **AL = off**), for low alarm only (i.e., set **AH = off**), or for both high and low alarm.

4.10 HY (Hysteresis Band)

It determines the hysteresis band between temperature of activating and deactivating alarms. It is also called differential band by some manufacturer. The unit is degree °C or °F. For example, Relay 1 is set as a non-latching process alarm with relays settings **RL1 = On, Lgc1 = RL_C, LAT1 = N, AH1 = 200, AL1 = 100** and **HY = 3** (temperature unit is F). For the high limit alarm, when the process temperature is greater and equal to 200°F, the relay will pull in; and when process temperature is less than 197°F, relay will drop off. For the low limit alarm, relay will pull in when process temperature is less than 100°F; and the relay will drop off when process temperature is greater or equal to 103°F.

4.11 AP (Alarm Pulse)

It determines the time duration of which a relay stays activated. The unit is second. Pulse length can be set from 1 to 100 seconds. This setting is only valid when the Relay Latching Mode is set to Pulsing, i.e., **LAt = P**.

5. Wiring Examples

5.1 Wire a 120V buzzer to alarm relays.

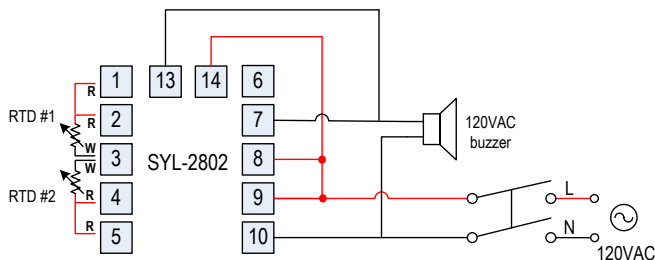

Figure 5. Wire a 120V buzzer to alarm relays.

5.2 Drive a solenoid valve and a small heater using alarm relays.

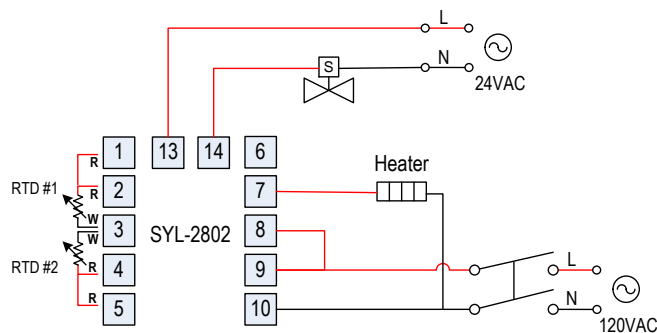

Figure 6. Drive a solenoid valve and a small heater using alarm relays.

(End)

Auber Instruments Inc.

5755 North Point Parkway, Suite 99,
 Alpharetta, GA 30022
www.auberins.com
 Email: info@auberins.com
 Tel: 770-569-8420

Copyright 2007-2016, Auber Instruments All Rights Reserved.
 No part of this manual shall be copied, reproduced, or transmitted in any way without the prior, written consent of Auber Instruments. Auber Instruments retains the exclusive rights to all information included in this document.