

Instruction Manual

TH102 TEMPERATURE AND HUMIDITY CONTROLLER INSTRUCTION MANUAL *Version 1.3*

1. Overview

This plug-n-play temperature and humidity controller can be used for sausage curing, green house and incubator applications. The controller has a two-line LED display, two output sockets, one sensor module and one input power cord. The top display shows the measured temperature value and bottom display shows the measured humidity value. The left output socket is for heating/cooling device. Right output socket is for humidifier/dehumidifier. The sensor module contains both temperature and humidity sensor.

2. Specification

Temperature Control Range	-40~80 °C, -40~176 °F
Temperature Resolution	0.1 °C (between -9.9 ~ 80 °C) 1 °C (between -40 ~ 10 °C) 0.1 °F (between -9.9~99.9 °F) 1 °F (between -40 ~ 10 °F, 100 ~176 °F)
Temperature Accuracy	0.5 °C
Temperature Control Mode	On/Off Control. Heating or Cooling
Temperature Control Output	15A, 120V or 240V AC *
Humidity Control Range	0~99.9% RH
Humidity Resolution	0.1% RH
Humidity Accuracy	3% RH
Humidity Control Mode	On/Off Control. Humidifying or Dehumidifying
Humidity Control Output	15A, 120V or 240V AC *
Operating Temperature	0~50 °C
Dimension	91x140x46mm
Input Power	85 ~242VAC, 50Hz/60Hz
Sensor Cable Length	6 ft (2m)
Power Cable Length	3 ft (1m)

* Please note: Although both temperature and humidity output can handle up to 15A, the combined total power of the two channels are limited to 1500 Watts due to the limitation of input power cord.

3. Front Panel



Figure 1. Front Panel

4. Setup Flow Chart

When the controller is powered on, it will display the measured temperature and humidity. The controller will keep running according to the saved setting. If the humidity or temperature sensor is shorted, the controller will display "Err". Please see Figure 2 for the flow chart to set the parameters.

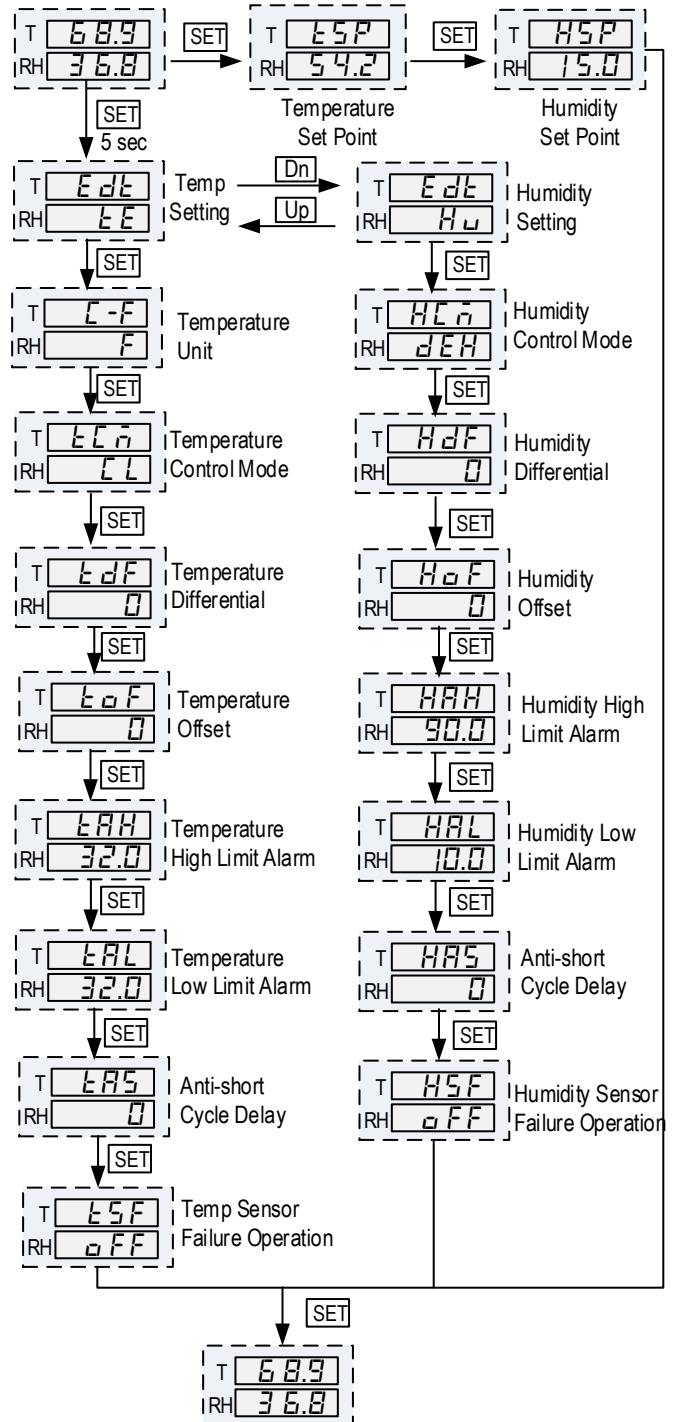

Figure 2. Flow Chart

5. Parameter Settings

To change the target temperature or humidity, press SET key momentarily. The controller will show tSP (temperature set point), press SET again will show HSP (humidity set point). Use Up or Down key to change the tSP or HSP.

To change the other parameters, press SET key for 5 seconds, the RH window will show tE or Hu (depending on which menu was set last time), press SET key to enter the set menu for temperature control or humidity control. Or press Down (or Up) key to change the RH (or Hu) window to Hu (or RH). Then press SET key to enter the set menu for humidity (or temperature) control.

To set up the while in the parameter setup mode, use Up or Down key to modify the parameter value. Then press SET key to confirm the change. The instrument will automatically exit if no key is pressed for 10 seconds. Please see the Table 1 for the parameters.

Table 1. Parameters Description

Code	Description	Setting range	Initial	Note
tSP <i>tSP</i>	Temperature Set Point	-40~176 °F -40~80 °C	75.0	1
HSP <i>HSP</i>	Humidity Set Point	0~99.9 % RH	40.0	
Edt <i>Edt</i>	Set Menu Selection	TE: Temp Menu Hu: Humidity Menu	TE	
C-F <i>C-F</i>	Temperature Unit	C: Celsius F:Fahrenheit	F	
tCM <i>tCM</i>	Temperature Control Mode	Ht: Heating Control CL: Cooling Control	CL	
TdF <i>TdF</i>	Temperature Control Differential	0~50.0	3.0	1
toF <i>toF</i>	Temperature Calibration Offset	-10.0~10.0	0	2
tAH <i>tAH</i>	Temperature High Limit Alarm	-40~176 °F -40~80 °C	95.0	3
tAL <i>tAL</i>	Temperature Low Limit Alarm	-40~176 °F -40~80 °C	32.0	
TAS <i>TAS</i>	Temperature Anti-short Cycle Delay (only for cooling)	0~12 min	0	4
TSF <i>TSF</i>	Temperature Sensor Failure Operation	on: Output energized oFF:Output de-energized	oFF	5
HCM <i>HCM</i>	Humidity Control Mode	deH: Dehumidifying H: Humidifying	deH	
HdF <i>HdF</i>	Humidity Control Differential	0~50.0	3.0	1
HoF <i>HoF</i>	Humidity Calibration Offset	-10.0~10.0	0	2
HAH <i>HAH</i>	Humidity High Limit Alarm	0~99.9	90.0	3
HAL <i>HAL</i>	Humidity Low Limit Alarm	0~99.9	10.0	
HAS <i>HAS</i>	Humidity Anti-short Cycle Delay (only for dehumidifying)	0~12 min	0	4
HSF <i>HSF</i>	Humidity Sensor Failure operation	on: Output energized oFF:Output de-energized	oFF	5

Note 1. For heating (or humidifying), the output will be off when the temperature (or humidity) reaches the set point; will be on again when the temperature (or humidity) drops down to tSP-tdF (or HSP-HdF).

For cooling (or dehumidifying), the output will be off when the temperature (or humidity) reaches the set point; will be on again when the temperature (or humidity) rises to tSP+tdF (or HSP+HdF).

Small differential gives tight control; large differential reduces the frequency of cycle on and off. It will extend the life of relay and compressor.

Note 2. The offset is used to set an input offset to compensate the error produced by the sensor or input signal itself. For example, for temperature, if the unit displays 37 °F when the actual temperature is 32 °F, setting parameter toF= - 5 will make the controller display 32 °F.

Note 3. The low limit alarm will be always lower than the high limit alarm. When the measured temperature (humidity) is higher than tAH (HAH), the temperature (humidity) high limit alarm will be on; when the measured temperature (humidity) is lower than tAL (HAL), the temperature (humidity) low limit alarm will be on.

When alarm is on, the display will be flashing between the measured value and alarm type. To mute the alarm when it is on, press the Down key momentarily. When the alarm is muted, the alarm indicator (see Figure 1, the small dot on the last digit) will be on. If the measured value gets out of the alarm zone then gets back to the alarm zone again, the alarm will be on again. To resume the alarm, press the Up key, the alarm indicator will be off.

To disable the alarm, set High Limit Alarm= Low Limit Alarm.

Note 4. When The controller is used for cooling (or dehumidifying control) and load is a compressor, it should not turn on the compressor when it is at high pressure (just after turned off). Otherwise, It may shorten the life of compressor. The Anti-Short Cycle Delay function can be used to prevent the rapid cycling of the compressor. It establishes the minimum time that the NO. contacts remains open (after reaching cutout) before closing again. The delay overrides any Load Demand and does not allow the NO. contacts to close until the set time-delay value has elapsed. It gives time to release the refrigerant pressure through evaporator. It is typically set to 4- 6 (minutes).

Note 5. The TSF (HSF) can be set to ON or OFF. When it is set to ON, the output will always be on when the sensor fails; when it is set to OFF, the output will always be off when the sensor fails.

For example, when the unit controls a refrigerator for food, you may want to set the TSF to ON if the sensor fails to keep the food cold. When it controls a heater, you may want to set the TSF to OFF for safety purpose .

6. How to install the sensor to the unit.

The connector of sensor contains a slot for correct pin connection . It also has a spring lock to prevent disconnections from accidental pulling on the cable. To install the to the unit, please align the slot of the female connector on the sensor to the red mark of the male connector on the unit, then hold the tail and push the female connector forward. To remove the connector, please pull the spring loaded collar of the female connector. Please see the Figure 3 and Figure 4 below for details.



Figure 3. Install the Sensor



Figure 4. Remove the Sensor

Auber Instruments Inc.

5755 North Point Parkway, Suite 99

Alpharetta, GA 30022

www.auberins.com

e-mail: info@auberins.com Tel: 770-569-8420

Copyright 2007-2015, Auber Instruments All Rights Reserved.
No part of this manual shall be copied, reproduced, or transmitted in any way without the prior, written consent of Auber Instruments.
Auber Instruments retains the exclusive rights to all information included in this document.