

Instruction Manual for AT100

Version 1.4



Figure 1. Thermometer identification

1. Thermometer identification

1. Connect to 12VDC power adapter
2. Connect to temperature sensor
3. Display window
4. Alarm indicator : blink when alarm is triggered
5. Peak value indicator : solid on when peak temperature is displayed / blink when it shows the time when peak temperature is reached
6. Set key: enter code / confirm input value
7. Shift key: shift digit / silence alarm buzzer
8. Down key: change digit value / move to former parameter / shift to peak temperature and the time when peak temperature is reached/ reset peak values
9. Up key : change digit value / move to next parameter / shift brightness

2. Keys for measurement operation

Figure 2 shows the function keys during the temperature measurement operation (The function keys for configuring the meter are discussed in the later section).



Figure 2 Function keys during temperature measurement operation

Notes:

1. When the temperature reaches the alarm temperature, the alarm indicator will flash and meter will start beeping. Press shift key once can temporarily silence the alarm. Alarm will be retriggered if the alarm set temperature is reached again. To permanently deactivate the alarm, set AH=AL.

2. Press down key once to show peak temperature; press again to show the time when peak temperature is reached (count from the start of temperature rising, display unit: seconds). If the temperature continued rising, a new peak temperature and its time will be recorded. They will be memorized even after power is restarted.

After power is restarted, previous recorded peak and its time will stay in the memory unless: 1) there is a new peak temperature higher than the previous peak, 2) or the memory has been reset. Hold the down key for 2 seconds will reset the peak temperature and its time to 0. The new time is counted from restarting the power or from reset (display unit: seconds).

3. Press up key once to show the dimmed display reading. Press again to show the normal brightness display reading. The brightness of the dimmed display is determined by the parameter "brit" described in the later section of the manual.

3. Connecting the meter and probe

This thermometer can be used with either thermocouple or RTD sensor. To operate it, connect 12VDC power adapter to terminal 1 and wall outlet. Connect thermocouple or RTD probe to terminal 2. **Please note: thermocouples have polarities.** From the front side view of the connector, the first pin from left on terminal 2 should be negative. The center pin is positive (shown as figure 3 below). However, when you install the thermocouple to the connector from back side with screws, please make sure the polarities also match with figure 3.

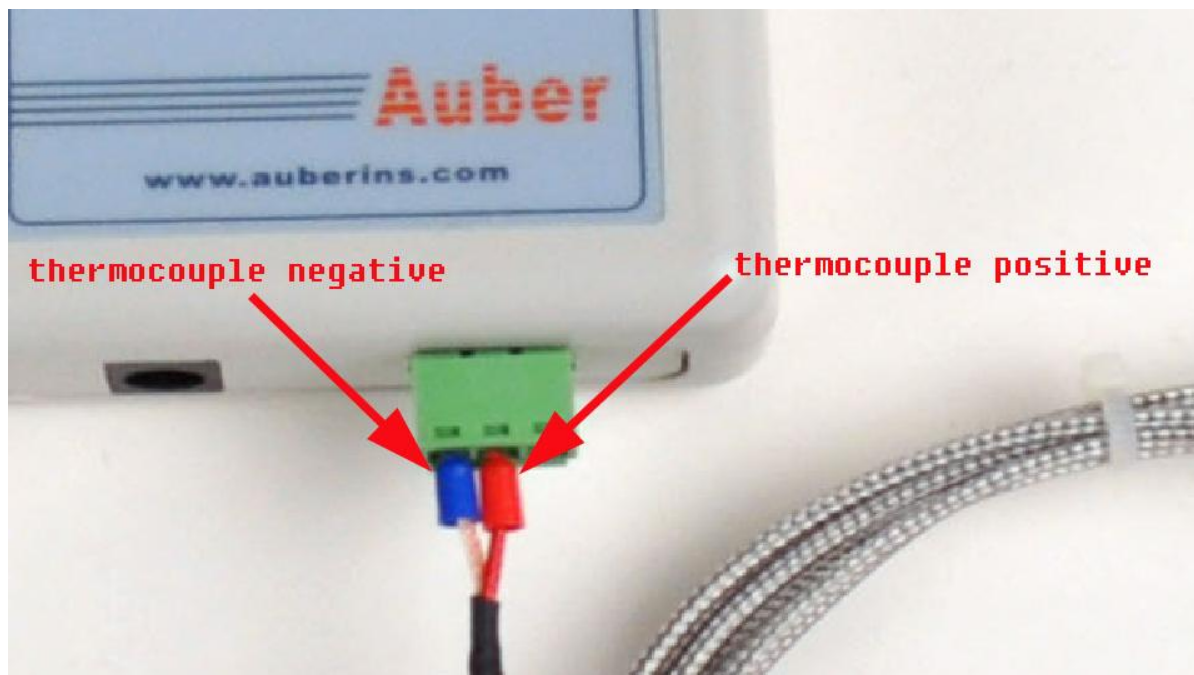

Figure 3. Thermocouple and meter connection

For three wire RTD sensor, the single wire should be connected to the first pin from right on terminal 2. For two wire RTD sensor, a jumper wire should be placed between the left and center pin through the connector.

The default setting for the input sensor type is K type thermocouple. To use with RTD sensor or other type of thermocouple, user need to reset parameter "Inty" (see below).

4. Alarm setting (code 0001)

The meter has two programmable alarms that can be set to turn on the buzzer at specific temperatures. They are controlled by parameters AH1, AL1, AH2, and AL2, which can be accessed by code 0001. AH1 (AH2) is the temperature at which the alarm turns on; AL1 (AL2) is the temperature at which the alarm turns off. When $AH1 > AL1$ (or $AH2 > AL2$), the alarm 1 (alarm 2) is set for high limit alarm. When $AH1 < AL1$ (or $AH2 < AL2$), the alarm 1 (alarm 2) is set for low limit alarm. For example, if $AH1=900$, $AL1=800$, when the temperature goes up to 900°F , the buzzer will be on; when the temperature drops down to 800°F , the buzzer will be off. However, if $AH1=180$, $AL1=185$, when the temperature drops down below 180°F , the buzzer will be on; when the temperature rise above 185°F , the buzzer will be off. User can press the shift key (>) to temporarily mute the buzzer. The alarm will activated again if the alarm set temperature is reached again. To permanently deactivate the alarm, set $AH1 = AL1$ (or $AH2 = AL2$). By default, alarm 2 is deactivated and $AH2 = AL2=25.0$

How to set alarm:

- (1) Press "set", enter code 0001, and "set" again to enter alarm setting menu ;
- (2) Press ^ and v to select AH1, AL1, AH2, AL2 ;
- (3) Press "set" to view the value of the parameter.
- (4) Press >, ^ and v to enter a new value.
- (5) Press "set" to confirm ;

- (6) Press ^ or v to select the new parameter.
- (7) To exit the menu, press "set" when "End" is displayed

The procedure is shown as the following flow chart in figure 4.

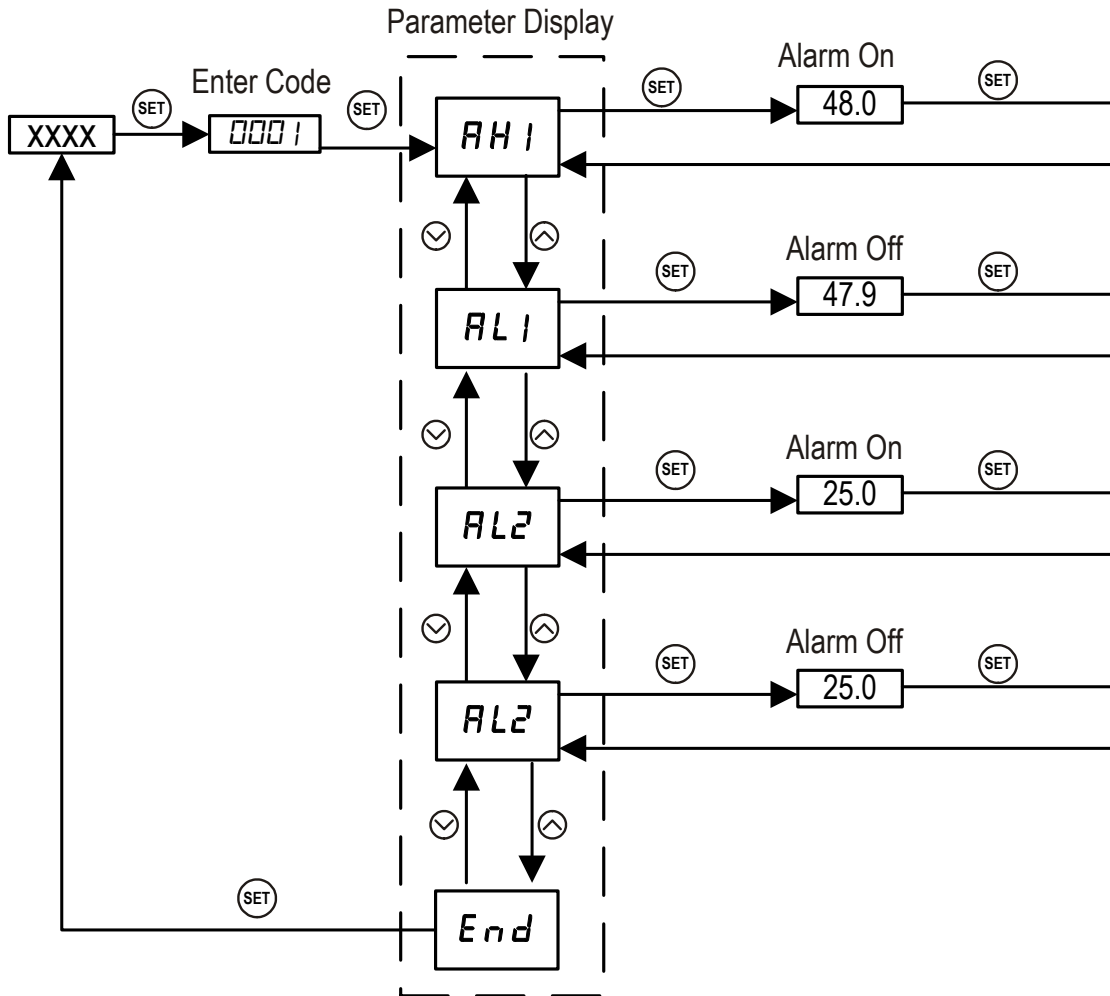

Figure 4. Flow chart of how to set the alarm

5. System configuration (code 0089)

Note: If you purchased the thermometer as a bundle (including the temperature probe), there is no need to change any of these parameters. But if you want to recalibrate the meter or reconfigure it, you need to read this section.

Table 1. System Configuration Parameters

Code		Description	Setting Range	Initial	Note
<i>Inty</i>	Inty	Input Sensor Type	See table 2	K	1
<i>PSb</i>	PSb	Input Offset	-100~100(deg)	0	2
<i>FILT</i>	FILT	Digital Filter	0~3	0	3
<i>C-F</i>	C-F	Display Unit	°C °F	°F	4
<i>Brit</i>	Brit	Brightness control	1-4	4	5
<i>End</i>	End	Exit			

Note for each parameter:

1. **Inty. Input sensor type.** This parameter defines the sensor type that is used for the thermometer. If you purchased the thermometer bundle, it is already set for the probe included in the package. You don't need to change it. If you are going to use a different sensor, you need to set it to the type of sensor you are using. Table 2 shows the symbol for each type of sensor.
2. **PSb. Calibration offset.** PSb is used to set an input offset to compensate the error produced by the sensor. For example, if the meter displays 5 °C when probe is in ice/water mixture, set PSb=-5, will make the meter display 0 °C.
3. **FILT. Digital Filter.** If measurement input fluctuates due to noise, a digital filter can be used to smooth the input. "FILT" may be configured in the range of 0 to 3. Stronger filtering increases the stability of the readout display, but causes more delay in response to the change in temperature. FILT=0 disables the filter.
4. **C-F. Temperature unit.** Set to C if you want to display Celsius. Set to F for Fahrenheit.
5. **Brit. Brightness control.** This parameter controls the LED display brightness. (The default value is 4 for the brightest display).
6. **End.** Exit the parameter setting mode.

Table 2. Temperature sensor code

Symbol		Description	Working Temperature Range
t	t	TC, Type T	-200~400 °C; -320~752 °F
r	r	TC, Type R	-50~1600 °C; -58~2900 °F
J	J	TC, Type J	-200~1200 °C; -320~2200 °F
WRE	WRE	TC, WRe3/25	0~2300 °C; 32~4200 °F
b	b	TC, Type B	350~1800 °C; 660~3300 °F
s	s	TC, Type S	-50~1600 °C; -58~2900 °F
k	k	TC, Type K	-200~1300 °C; -320~2400 °F
e	e	TC, Type E	-200~900 °C; -320~1650 °F
P10.0	P10.0	RTD, Pt100	-99.9~600.0 °C; -99.9~999.9 °F
P100	P100	RTD, Pt100	-200~600 °C; -320~1100 °F
Cu50	Cu50	RTD, Cu50	-50.0~150.0 °C; -60~300 °F

The flow chart in figure 5 shows how the system configuration parameters can be accessed.

- (1) Press “set”, enter code 0089, and “set” again to enter system configuration menu ;
- (2) Press ^ or v to select the parameter to be changed.
- (3) Press “set” to view the value of the parameter.
- (4) Press >, ^ and v to enter a new value.
- (5) Press “set” to confirm ;
- (6) Press ^ or v to select the new parameter.
- (7) To exit the menu, press “set” when “End” is displayed.

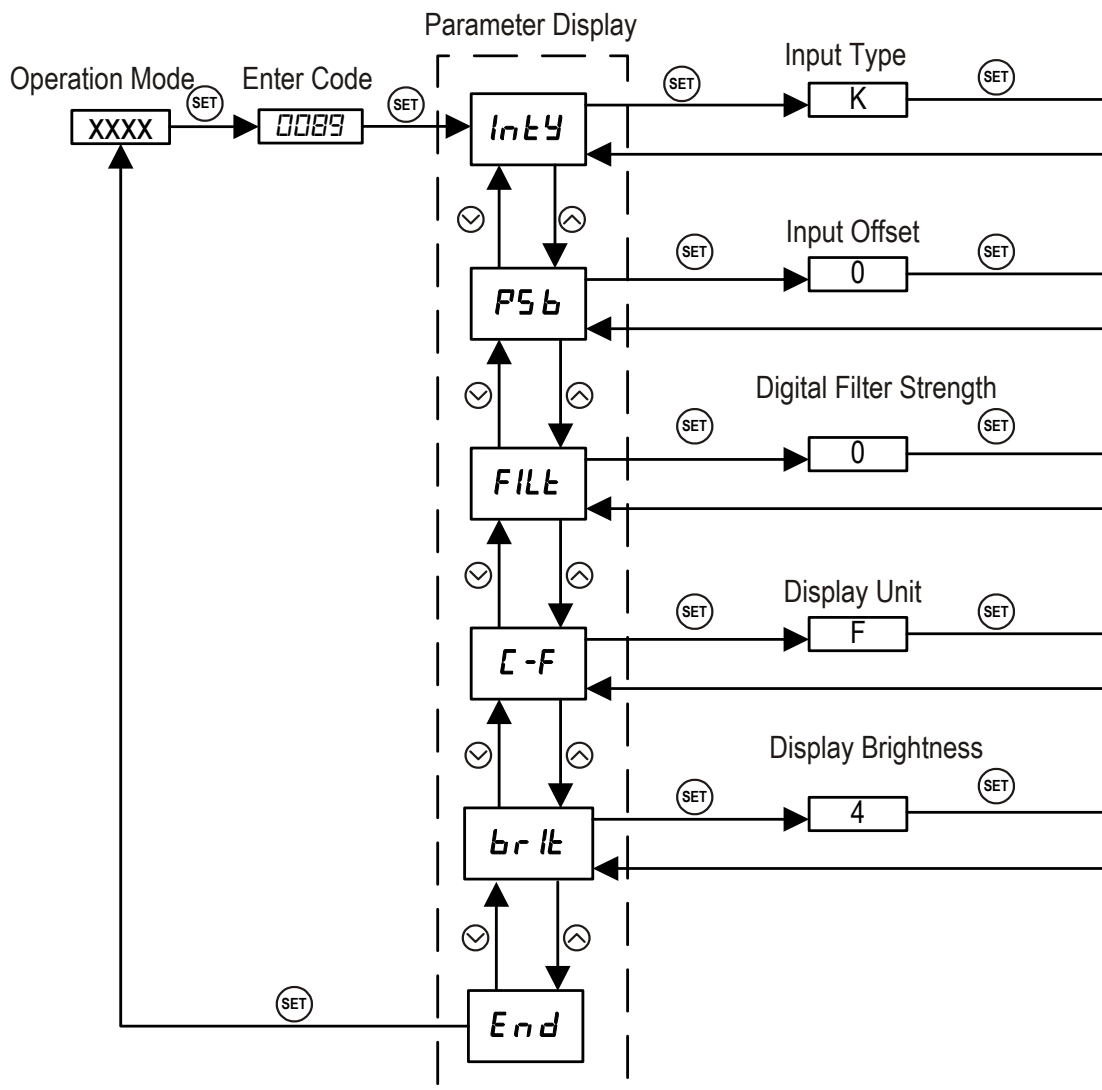

Figure 5. Flow chart of how to set the parameters

6. Placing the meter

The operating environment temperature for the meter is from -20-50C (or, 0-100F). The meter should be placed away from high heat to protect the plastic housing and electronics. Two mounting options are provided.

- 1) A pair of Velcro® fastener. The Velcro has a pressure sensitive adhesive backing. You can remove the protecting film from the hook piece and stick it to the back of the meter (see figure 6). Then remove the protecting film from the loop piece and install it onto the wall. Please note that the pressure sensitive adhesive on Velcro is industrial grade with strong holding force. It needs to be stick on solid surface. Don't put it on a drywall because it may peel off the paint if you decided to remove it later
- 2) A stainless steel mounting plate. The plate allows the meter to be hung on a hook or on a nail. It also allows the meter to be permanently mounted with a screw. The bottom part of the stainless steel mounting plate is covered with pressure sensitive adhesive. To install it onto the meter, peel off the pink colored releasing film; press it firmly onto the back of the meter (see figure 6).



Fig 6. Left, using Velcro for mounting. Right, using stainless steel plate for mounting.

Copyright 2007-2016, Auber Instruments All Rights Reserved.

No part of this manual shall be copied, reproduced, or transmitted in any way without the prior, written consent of Auber Instruments.

Auber Instruments retains the exclusive rights to all information included in this document.