

Guide for Controlling the Bradley Smoker

For Model WS-1500EPM

Version 1.1

Auber Instruments

5755 North Point Parkway, Suite 99

Alpharetta, GA 30022

770-569-8420

www.auberins.com

May. 2013

Introduction

Thank you for purchasing the Auber WS series temperature controller. We sincerely appreciate your decision and trust that our machine will meet your expectations in both the quality of the result and the value of our product. While we are delighted that you may be anxious to operate the controller for your project, a few minutes of your time reading through this manual will only serve to enhance your experience in the months and years ahead. In particular, we urge you to read through the safety warnings below. Although this plug-and-play controller is very easy to operate, the process involves high temperature and high wattage appliances, and your safety is paramount.



SAFETY WARNINGS

- This controller is designed to be used only with devices that have limited power and their own thermal cutoff protection, such as a thermostat or thermal fuse in case of controller failure.
- Do not place any objects on the top of the controller surface as it is used to vent excess heat during its operation.
- The maximum electric current this controller can handle is 15 Ampere. For 120 volt AC in US and Canada, this limits the heater power to 1800 watts. Due to its compact size and the splash proof design for kitchen applications, the controller has a limited ability to dissipate the heat generated by the internal solid state relay during the initial heat up. The initial full power heat up process cannot be more than 90 minutes. If the system needs a longer time to warm up, please read Appendix 1 "Managing the heat generated by the controller"
- **Always place the sensor in the controlled subject when the controller is on.** Before turning on the controller, please make sure the sensor is placed inside the container to be controlled. Leaving the sensor outside will form an open loop operation, and the controller will assume the temperature is low even if the controlled subject is already very hot. The controller will provide full power to the heater and not only overheat the controller, but also damage your appliance possibly

causing a fire. If the sensor is not permanently mounted on the system or is left outside of system you should enable the open loop alarm function.

- This controller is designed to control the devices recommended by Auber Instruments only. Using it to control a non-recommended device can be dangerous and cause fire. Auber Instruments is not liable for damages caused by misuse of the controller. If you are not sure the controller can be used, please contact Auber Instruments before use.
- If an abnormal display or noise is observed, turn the controller off, unplug the power cord and contact the manufacturer before using it again.
- Clean the controller only when it is cool and unplugged.
- Do not allow children to operate the controller.

Operating Instructions

This guide is for using the temperature controller with the Bradley Smoker only. The WS-1500EPM controller can also be used for controlling any other household cooking devices under 1800 watts (120VAC). For complete information on how to set up the controller for other applications, please read the WS-1500EPM manual

1) Description of the controller.

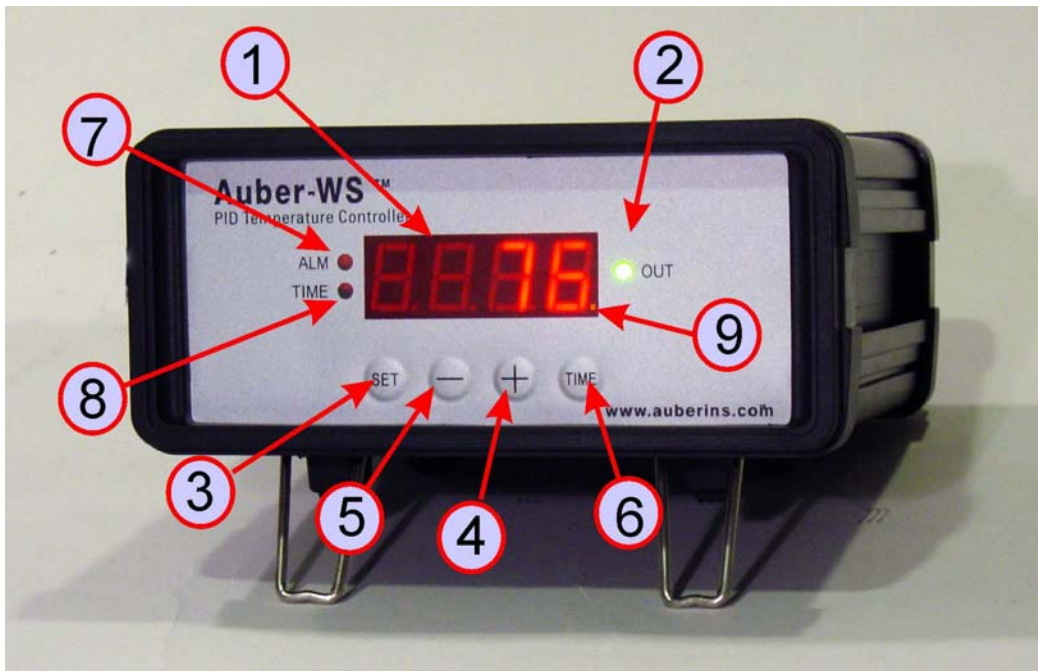

Figure 1. Front Panel

- (1) Parameter Window (LED)** - For displaying temperature values and controller's system parameters.
- (2) Output status indicator** - In normal mode, this LED indicates the heater status. When it is on (lit), the heater is powered. When it is off, the heater power is off. When it is flashing, it means the heater is on and off intermittently to reduce the power output. It should be synchronized with the power light on the cooking device.
- (3) SET Key** - For showing current temperature settings, getting into parameters setting mode and confirming various actions taken.
- (4) "+" Key** - To increment displayed value.
- (5) "-" Key** - To decrement displayed value.
- (6) Time Key** - Change the Parameter Window between current timer and temperature values, when pressed.
- (7) Alarm indicator** - Lit when the alarm is on.
- (8) Timer status indicator** - In normal mode, when "(8)" is on and "(9)" is flashing, LED shows the time passed since it's powered on.
- (9) Mode indicator** - the small "dot" is used to indicate what mode the controller is in.
 - When it is flashing and "(8)" stays on, "(1)" is the time that has elapsed since it's powered on.
 - When it is flashing "(8)" is off, the controller is in the parameter setting mode. "(1)" is the value can be changed by using (4) and (5) key.

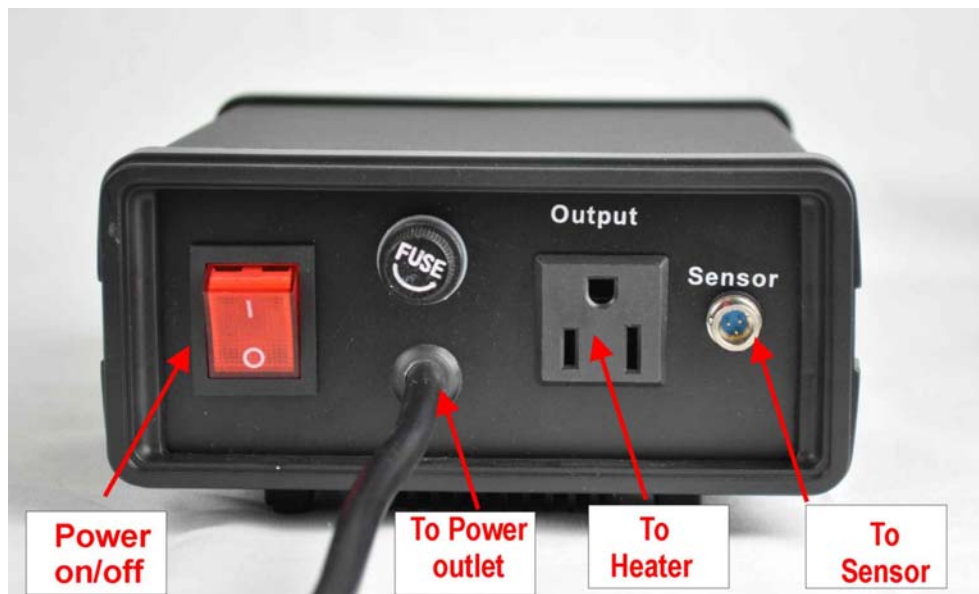

Figure 2. Back Panel

2) Connecting the controller

This set up is good for the "Original", Stainless Steel, and Digital Bradley Smoker.

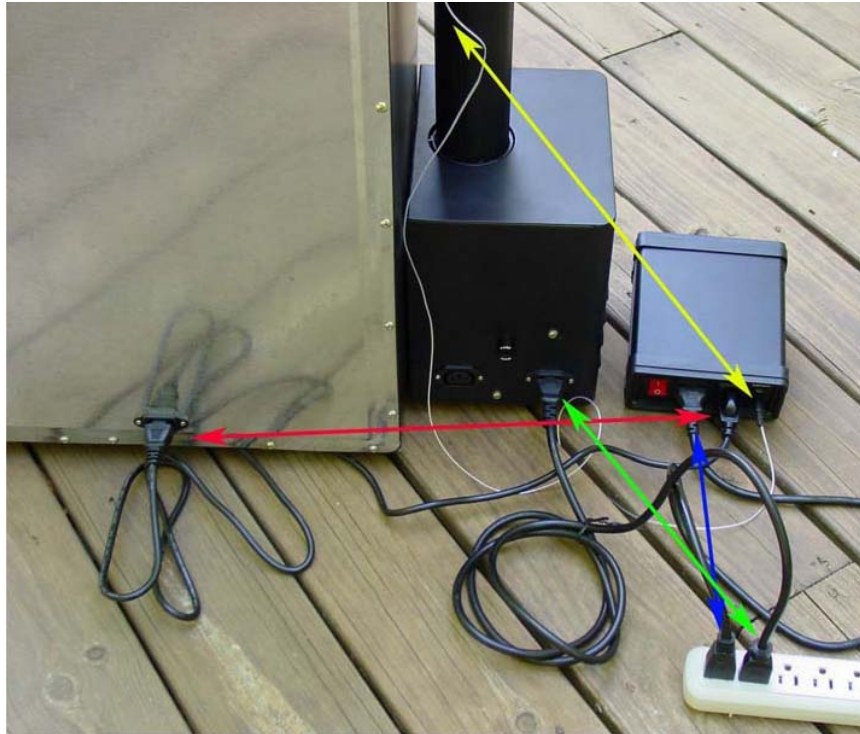

Figure 3. Power connection of the controller and smoker.

The input of the controller is connected to the power strip (blue arrows). The generator is connected to the power strip by the power cord from Bradley (green arrows). The controller output is connected to the smoker by an 18 AWG power cord (red arrows). The sensor is connected to the sensor port on the controller (yellow arrows).

Install the sensor. The sensor is plugged into the sensor port on the controller (**Error! Reference source not found.**). The connector for the sensor contains a slot for correct pin connection. It also has a spring lock to prevent disconnections by accidental pulling on the cable. The following pictures show how to install and remove it.



Figure 4. How to install the sensor.



Figure 5. How to remove the sensor.

The tip of the sensor is dropped into the damper hole. It is held in place by a piece of tape on the top of the smoker tower (Figure 6)

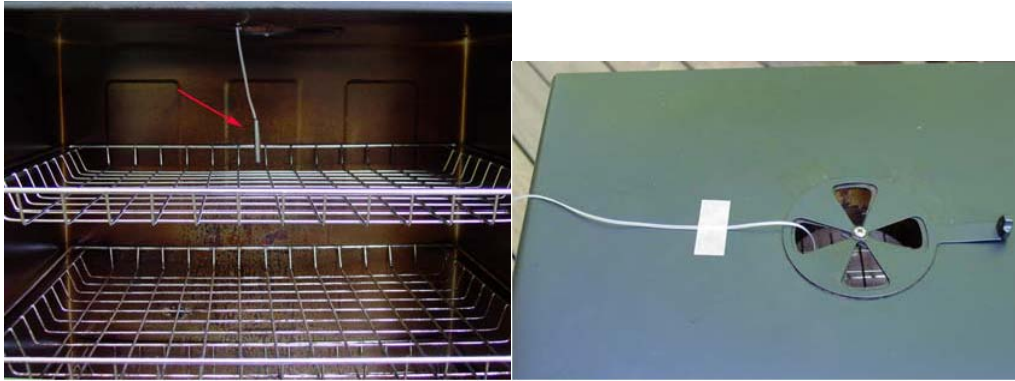

Figure 6. Sensor position. Left, the sensor should be placed close to the food but high enough so that it does not touch the food. Right, hold the sensor in place by a piece of tape.

For the “Original” and Stainless Steel Bradley smoker, the Temperature Heat Control Switch on the smoker tower should be slid to the Hi position (Most right).

For the Bradley Digital Smoker, the original sensor cable from the smoker should be connected between the generator and smoker.

The controller is ready to power up.

3) The PID parameter for Bradley Smoker

This controller is shipped with parameters set for commercial rice cookers. You can try to use the recommended PID parameters listed in Table 1. These are the parameter we obtained from tuning the system manually.

Table 1. Recommend PID parameter for Bradley Smoker.

| Symbol | P | I | d |
|----------------|----------|----------|----------|
| Display | <i>P</i> | <i>I</i> | <i>d</i> |
| Bradley Smoker | 70 | 600 | 150 |

This group of parameters can be accessed by input code 166. Figure 7 is the flow chart that shows how the parameters can be changed.

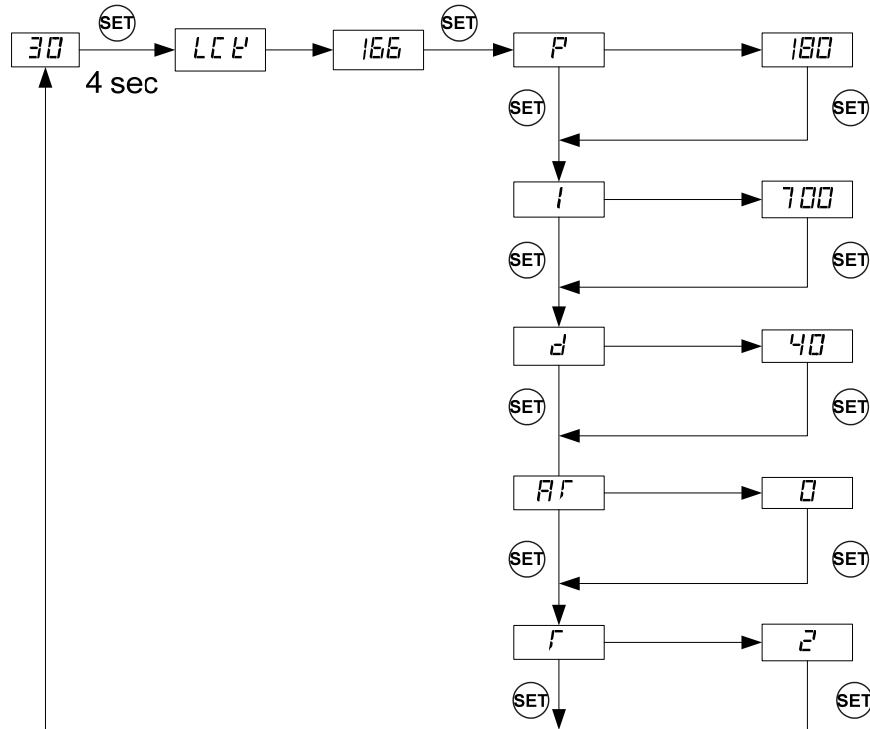

Figure 7. Code 166 Parameter setup flow chart

Press and hold SET key for 4 seconds until the LED displays “LCK”. Then, release the SET key. The display will show “0”. To enter parameters setting mode, you need to key in the pass code. Use “+” and “-” keys to adjust the display to 166 (the pass code) and press SET. The LED will show “P” for a second and then its P setting value, Use “+” and “-” keys to change the setting. When finished, press the SET again to confirm the change. The display will show the “I” for a second and its I setting value next, use the same “P” setting procedure to set the I value. When finished, press the SET again to confirm the change. The display will show the “d” for a second and its value next. Use the same “P” setting procedure to set the d value. When finished, press the SET again to confirm the change. The next setting is AI, the auto-tune. Use “+” to set the value to 1 and press SET will activate the auto-tune. The next setting is the “t” setting, use “-” and “+” to set the cycle time value. This value should remain 2 for most application. After the PID parameters are changed, the controller needs to be turned off and on again for the best result.

4) Programming the smoking temperature profile.

A total of 6 steps can be programmed for this controller. Each step contains the temperature (C0X) and time duration (T0X) setting. They are represented by the symbol C0X and T0X, where “X” is the step number (e.g. Step 4 temperature is represented by C04 and step 4 time is represented by T04).

The character, "T", is displayed as the symbol, "r". Time is defined as the duration between the last step and the next step. Please make sure the time is long enough for the heater to heat up the oven. If the time is set too short, the temperature may not be able to reach the current step temperature setting, before it jumps to the next step. The time unit is in minutes with 1 minute resolution. If the recipe only needs one step, you can program the time of the rest of the steps to zero.

To program the temperature profile, press SET key once. The display will show C01 for one second and then display the temperature setting for step 1. Use "+" and "-" keys to change the setting. When finished, press the SET again to confirm the change. The display will show T01 for a second and then change to the cook time setting for step 1. Use "+" and "-" keys to change the setting. When finished, press the SET again to confirm the change. The display will go the step 2 setting. The following is the flow chart for the setting procedure.

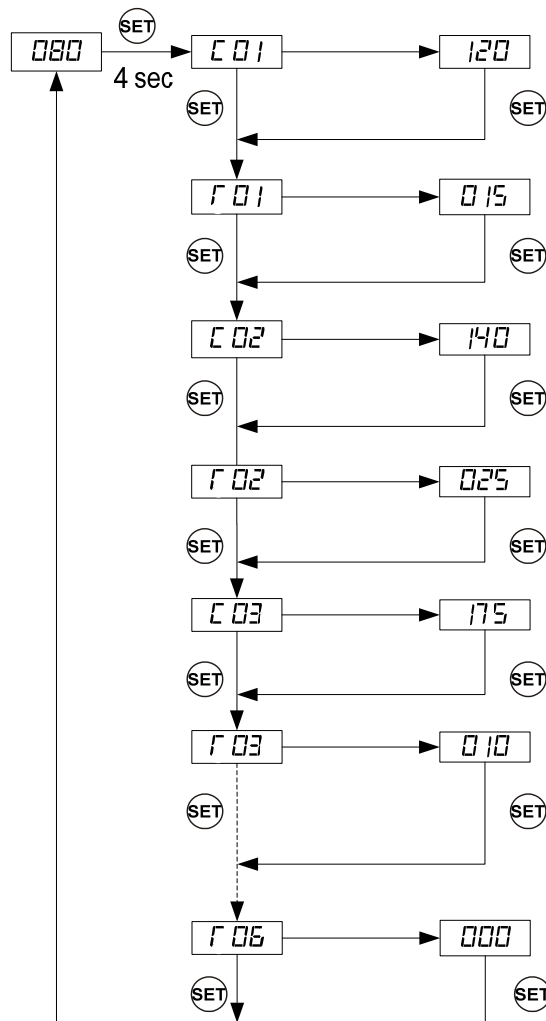

Figure 8. Temperature profile programming flow chart.

The temperature setting will not be changed if SET is not pressed (confirmed). After programming the necessary steps for cooking, you can finish programming by pressing the SET continuously until it passed T06 and display the current temperature. You can also leave the controller alone. The display will return to the normal display mode if no key is pressed within 15 seconds.

Here is the setting example for smoking the salmon. The temperature profile is to start at 120 °F for 90 minutes of smoking, rise to 132 °F for 150 minutes and finish at 175 °F for 60 minutes. The recipe is from Kummok:

<http://forum.bradleymoker.com/index.php?topic=107.0>

If you like more moisture in the fish and serve it within a day, the last step (175 °F) can be eliminated.

| Step # | Temp (F) | Step # | Time (minute) |
|--------|----------|--------|---------------|
| C01 | 120 | T01 | 090 |
| C02 | 132 | T02 | 150 |
| C03 | 175 | T03 | 60 |
| C04 | 000 | T04 | 00.0 |
| C05 | 000 | T05 | 00.0 |
| C06 | 000 | T06 | 00.0 |