

**Instruction Manual**

# SYL-1615 Temperature Controller for Charcoal Smoker

Version 1.3 (May, 2017)

## 1. Features

This PID controller is for controlling the temperature of charcoal smoker. It will regulate the on/off time interval of a 12 VDC blower to stabilize the temperature in the charcoal smoker. It has built-in solid state relay that can drive a 12 VDC operated blower up to 60 CFM. It has a built-in buzzer that can be set for both low limit and high limit alarm. The system includes a controller, an AC to 12 VDC adaptor, a K type thermocouple. Also included is power plug that fits the control output jack. User needs to install the plug to a 12 VDC operated blower with adequate wind speed (6.5 CFM Fan is the most common for medium/large home-use smokers).

## 2. Specifications

AC adaptor: 100 – 240 V, 50/60Hz input. 12 VDC, 1 Amp output.  
 Power consumption: < 2 W  
 Sampling rate: 4 samples/second  
 Accuracy: 0.2% full scale  
 Display range: -320 ~ 2400°F, or -200 ~ 1300°C  
 SSR output for Fan: 12 VDC, 1 Amp \*  
 LED display: 0.39 inch, red  
 Control Mode: PID, on/off, Limit.  
 Alarm: Two set points with buzzer sound.  
 Sensor: K type thermocouple, -300 ~ 550°F (-200 ~ 300°C) \*\*  
 Dimension: 2.8" x 3.5" x 1.2" (70 x 90 x 30 mm)

### Note

\* Up to 3 Amp can be supplied when more powerful power supply is used.  
 \*\* Eight other types of thermocouple can also be accepted (see table 4)

## 3. Front Panel



Figure 1. Front panel of SYL-1615.

- ① LED display
- ② OUT - SSR output indicator  
(AT) - Blinking during auto-tune process
- ③ Set / confirm
- ④ Shift digit / mute alarm / start auto-tune
- ⑤ Value decrement / select previous parameter

- ⑥ Value increment / select next parameter
- ⑦ AL - alarm Indicator

## 4. Connecting the Controller

Figure 2 shows the terminals of the controller. Connect the AC to 12 VDC power adaptor to the POWER connector (①) and wall outlet. Connect the fan connector to the OUTPUT connector (②). The polarity for this socket is center pin positive (+), outer collar negative (-). Connect the type K thermocouple to the INPUT socket (③). Please note that thermocouple connector also has polarity. The wide blade should go to the wide slot.

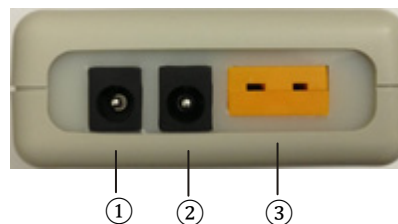

Figure 2. Connectors of SYL-1615 (bottom view).

- ① POWER – 12 V Power supply input
- ② OUT - Fan control output
- ③ INPUT - Temperature probe input

## 5. Parameter Settings

### 5.1. Set Temperature and Alarms (accessed by code 0001)

Table 1. Set temperature and alarm parameters

Symbol	Description	Range	Initial	Note
SV	SV	Set temperature	200	Note 1
AH1	AH1	Alarm 1 turn on temp.	250	Note 2
AL1	AL1	Alarm 1 turn off temp.	249	
AH2	AH2	Alarm 2 turn on temp.	250	
AL2	AL2	Alarm 2 turn off temp.	250	
END	END	Exit		

### Note 1. Set Temperature.

There are two ways to set the target temperature.

a. During the normal operation mode, press  $\Delta$  or  $\nabla$  once to switch the display from process value (PV) to set value (SV, or target temperature). The display will start to blink. Press  $\Delta$  or  $\nabla$  again to increase or decrease the SV. When finished, wait 8 seconds and the settings will take effect automatically (the display will stop blinking).

b. Press SET key once. Use  $\Delta$ ,  $\nabla$  and V keys to enter code 0001. Press SET key to confirm, then the display would be SV (Su). Press SET key again to display the SV setting. Use  $\Delta$ ,  $\nabla$  and V keys to enter the new SV value and press SET to confirm. Press V key to change the display to END. Then, press

SET to exit. You can also ignore the steps after confirmation of **SV**. The controller will return to normal operation mode automatically if no key is pressed for 1 minute. The flow chart below shows how to set the **SV** and alarms in details.

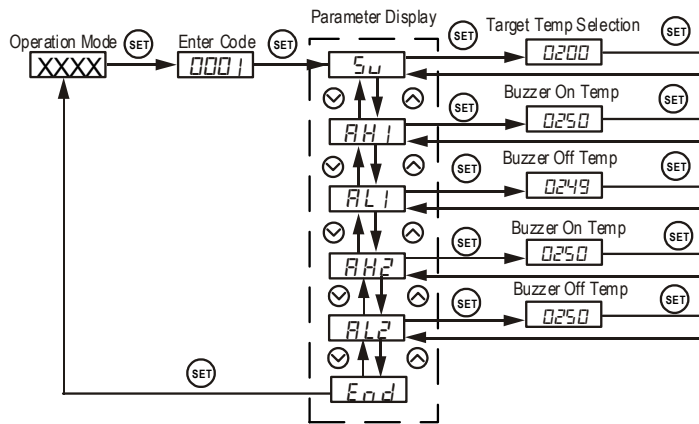

Figure 3. Flow chart for how to set target temperature and alarm.

**Note 2. alarms**

The controller offers two alarms that can be set to turn on the buzzer at specific temperatures. The first alarm is controlled by parameters **AH1** and **AL1**. The initial setting will turn on the buzzer at 250°F and off when temperature drops below 249°F. The second alarm is controlled by parameters **AH2** and **AL2**. The initial setting of the second alarm is deactivated. It can be set as low alarm to send warning when charcoal is low.

**AH1** and **AH2** are the temperatures to turn buzzer on; **AL1** and **AL2** are the temperatures to turn buzzer off. When **AH1 > AL1** (or **AH2 > AL2**), the Alarm 1 (or Alarm 2) is set as absolute high alarm as shown in Figure 4 below. When **AH1 < AL1** (or **AH2 < AL2**), the Alarm 1 (or Alarm 2) is set as absolute low alarm as shown in Figure 5 below. When **AH1 = AL1** (or **AH2 = AL2**), the alarm is deactivated.

For example, if **AH1 = 250**, **AL1 = 249**, when the temperature goes up to 250°F, the buzzer will be on; when the temperature drops down to 249°F, the buzzer will be off. If **AH2 = 180**, **AL2 = 185**, when the temperature drops down to 180°F, the buzzer will be on; when the temperature goes up to 185°F, the buzzer will be off.

User can press the shift key (>) to temporarily mute the buzzer sound. The alarm will buzz again if the alarm set temperature is reached again. To permanently deactivate the alarm, set **AH1 = AL1** or **AH2 = AL2**. Please see flow chart in Figure 3 on how to set the value.

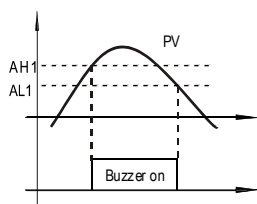

Figure 4. Absolute high alarm

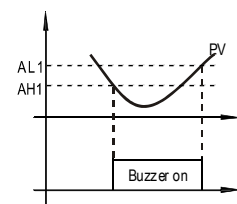

Figure 5. Absolute low alarm

The contents below are for reference and advanced applications. Most BBQ smoker users do not need to read beyond this point.

**5.2 PID parameter setting (accessed by code 0036)**

The values of P, I and D parameters are critical for good response time, accuracy and stability of the system. The values of the PID parameters have been optimized for charcoal grill application. User should not change it unless the result is not satisfactory. In that case, you can use the Auto-Tune function to automatically determine these parameters. If auto-tuning result is not satisfactory, you can manually fine-tune the PID constants for improved performance.

Setting PID parameters is similar to the setting of the Temperature and Alarm Parameter as shown in the flow chart of Figure 3. The difference is that these parameters are accessed by enter code 0036 instead of 0001.

Table 2. PID and relevant parameters.

Symbol	Description	Range	Initial	Note	
P	P	Proportional Constant	0.1~99.9 (%)	1.2	Note 3
i	I	Integral Time	2~1999 (Sec)	300	Note 4
d	D	Derivative Time	0~399 (Sec)	70	Note 5
SouF	SouF	Damp Constant	0.1~1.0	0.7	Note 6
ot	ot	Cycle Rate	2~199 (Sec)	15	Note 7
FILt	FILt	Digital Filter Strength	0~3	0	Note 8
End	End	Exit			

**Note 3. Proportional Constant (P):** When **P** increases, the system is more stable. When **P** decreases, the system is less stable. If the **P** is too small, the system would be oscillatory or even non-convergent.

**Note 4. Integral time (I):** Brings the system up to the set value by adding a constant to the output that is proportional to how far the process value (**PV**) is from the set value (**SV**) and how long it has been there. When I value is decreased, the response speed is faster but the system is less stable. When I value is increased, the respond speed is slower, but the system is more stable. When I is set to "0", then the controller become to a PD control.

**Note 5. Derivative time (d):** Responds to the rate of **PV** change, so that the controller can compensate in advance before **|SV-PV|** gets too big. A larger number increases its action. Setting d-value too small or too large would decrease system stability, cause oscillation or even non-convergence.

**Note 6. Damp constant (SouF):** The parameter is controlled by the artificial intelligence of the controller. This constant helps the PID control quality. When its value is too high, the system will be over damped. When its value is too low, the system may overshoot.



Figure 6. Damp constant

**Note 7. Cycle rate (ot):** It is the time period that the controller uses to calculate its output. The initial value is set to 15 seconds for charcoal smoker control. Short time causes the fan to pulse at higher frequency. Longer time may reduce the quality of control

**Note 8.** Digital Filter (Filt): can be set as 0, 1, 2, 3. Filt = 0, filter is disabled; Filt = 3, strongest filtering effect. Stronger filtering increases the stability of readout display, but causes more delay in the response to changes in temperature.

**5.3 System Configuration Parameters (accessed by code 0089)**

Table 3. System configuration parameter setting

Symbol	Description	Range	Initial	Note
<i>Inty</i>	Inty	Input Sensor Type	See Appendix 1	K
<i>Outy</i>	Outy	Control Output Mode	0,1,2,3,4,5,6	2 Note 9
<i>Hy</i>	Hy	Hysteresis Band	0~999	3 Note 10
<i>Atdu</i>	Atdu	Autotune Offset	0~200	10 Note 11
<i>PSb</i>	PSb	Input Offset	-1000~1000	0 Note 12
<i>Rd</i>	Rd	Control Function	0: heating; 1: Cooling	0 Note 13
<i>Corf</i>	Corf	Display Unit	0: °C; 1: °F	1 Note 14
<i>End</i>	End	Exit		

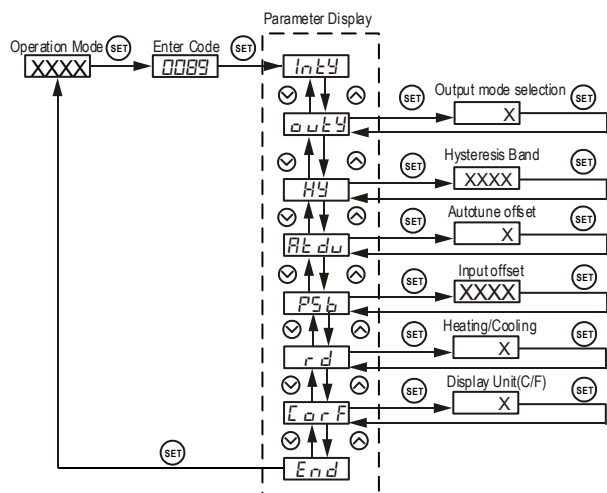

Figure 7. The system setup flow chart

**Note 9.** The value of **outy** determines the control mode. When **outy** is set to, 2: PID control mode. 3: On/off control mode. 6: Limit control mode.

The new **outy** setting will not take effect if the **outy** is changed until the controller is restarted.

Setting value for 0, 1, 4, 5 should not be used for this controller.

**Note 10.** Hy is only used when controller is in on/off or limit control mode. It sets the hysteresis band for the controller.

**Note 11.** The auto-tune offset will shift the **SV** value down by the **Atdu** value during the auto tune process. It will prevent the system from damage due to overheating during auto-tuning.

**Note 12.** Calibration offset, **PSb** is used to set an input offset to compensate the error produced by the sensor. For example, if the meter displays 5°C when probe is in ice/water mixture, setting **PSb** = -5, will make the controller

display 0 °C. To set negative value, shift to the very left digit, press down key until it shows “-”.

**Note 13.** Rd is for system function selection, 1 for cooling, 0 for heating.

**Note 14.** Display unit selection **Corf**: 0 for Celsius (°C); 1 for Fahrenheit (°F).

**6. Auto-Tune**

The Auto-tune is a feature to let the controller automatically determine the PID constants to control the object efficiently. The auto-tune function will heat up the system then let it cool down. It will repeat this about three times. Based on the response time of the system, the built-in artificial intelligence program will calculate and set the PID parameters for the controller. The duration of auto-tune depends on how long to heat up and cool down the system. If the system is very slow to cool down, the auto tuning could take a long time.

**6.1 Auto-tune curve**

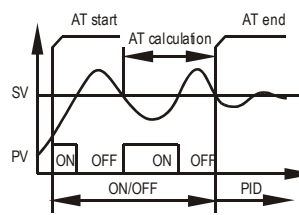

Figure 8. Auto tuning

**6.2 Auto-tune process**

1) To active auto tuning: Press and hold > key until the “AT” indicator starts to blink, which indicates auto-tuning is in process. When “AT” stops blinking, the auto-tuning is finished. The parameter obtained from auto-tune will be remembered by the controller unless it is manually changed.

2) To stop auto-tuning: During auto-tuning process, press and hold > until “AT” indicator stops blinking. Then the previous PID parameters value are resumed.

**7. On/off Control Mode**

On/off control mode always work even if the system response is unknown. Instead of holding the temperature at a specific point as the PID mode, on/off control mode will hold the temperature is a narrow range. Instead of setting the **P**, **I** and **D** parameters, you just need to set the target temperature and the hysteresis band. It works similar to a mechanical thermostat. When the temperature passes the set point, the fan will be turned off. When the temperature drops back to below the hysteresis band (dead band) the fan will be on again.

To use the on/off mode, set **outy** to 3. Then, set the **Hy** to the desired range based on control precision requirement. Smaller **Hy** results in tighter temperature control but also cause the on/off action more frequent. In the PID parameters menu (code 0036), only **ot** and **FILT** is used. **P**, **I**, **D** and **SouF** are not meaningful when controller is in on/off mode.

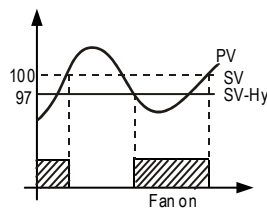

When heating, and outy=3,  
 If  $PV \leq (SV - Hy)$ , relay on  
 If  $PV \geq SV$ , relay off  
 (SV=100, Hy=3)

Figure 9. On/off control mode

**8. Limit Control Mode**

The limit control mode will shut the fan off when the (SV) is reached. The fan will not be turned on again until the controller is reset manually (press the SET for 5 seconds). When powered on, it will not start the fan until reset button pressed. The controller can't be reset when the temperature is within the hysteresis band (Hy).

To use the Limit control mode, set **Outy** = 6. Then, set the **Hy** to the range that you want reset to be blocked. To start the fan, press SET key for 5 seconds or until the output indicator is on.

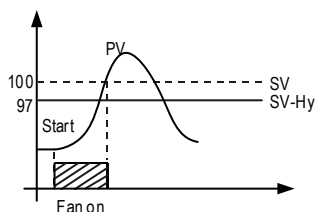

When heating, Outy=6  
 If  $PV \leq (SV - Hy)$ , relay on  
 If  $PV \geq SV$ , relay off  
 (SV=100, Hy=3)

Figure 10. Limit control mode

**9. Placing the Controller**

The operating environment temperature for the meter is from -20 - 50°C (or, 0 - 100°F). The meter should be placed away from high heat to protect the plastic housing and electronics. Two mounting options are provided.



Figure 11. Left, using Velcro for mounting.  
 Right, using stainless steel plate for mounting.

1) A pair of Velcro® fastener. The Velcro has a pressure sensitive adhesive backing. You can remove the protecting film from the hook piece and stick it to the back of the meter (see figure 11). Then remove the protecting film from the loop piece and install it onto the wall. Please note that the pressure sensitive

adhesive on Velcro is industrial grade with strong holding force. It needs to be stick on solid surface. Don't put it on a drywall because it may peel off the paint if you decided to remove it later

2) A stainless steel mounting plate. The plate allows the meter to be hung on a hook or on a nail. It also allows the meter to be permanently mounted with a screw. The bottom part of the stainless steel mounting plate is covered with pressure sensitive adhesive. To install it onto the meter, peel off the pink colored releasing film; press it firmly onto the back of the meter (see figure 11).

**10. Trouble Shooting**

**10.1 Display EEEE**

This is an input error message. The possible reasons are: The sensor is not connected correctly; the input setting is wrong type; or the sensor is defective. If this happens, you can short two slots of the female thermocouple connector on the controller with a paper clip or copper wire. If the display shows the ambient temperature, the thermocouple is defective. If it still displays EEEE, check the input setting, **Inty**, to make sure it is set to the right thermocouple type. If **Inty** setting is correct, the controller is defective.

**10.2 No Output**

The "OUT" LED is synchronized with output. If there is no output when it is supposed to, check the OUT Indicator first. If it is not lit, the controller parameter setting is wrong.

**10.3 Poor Accuracy**

Please make sure calibration is done by immersing the probe in liquid. Comparing with reference in air is not recommended because response time of sensor depends on its mass. Some of our sensor has response time >10 minutes in the air. When the error is larger than 5°F, the most common problem is improper connection between the thermocouple and the controller. The thermocouple needs to be connected directly to the controller unless an extension wire is used. A copper connector, copper wire, or thermocouple extension wire with wrong polarity connected on the thermocouple will cause the reading drift more than 5°F.

**10.4 Use the controller and blower with you smoker**

A lot of factors can affect the temperature control in a smoker. The temperature in a smoker pit is mainly decided by two factors: the fuel and the air flow. When you use a PID controller and a blower on a BBQ or smoker, the goal is to let the controller to take over the control of the air flow. Here are some quick tips:

- 1) Use only one lower vent for the blower, seal the gaps, and close all other lower vent if there is any.
- 2) Close the top vent to about 1/16" (1.6 mm) wide for Kamado style smokers, or 1/4" for single-wall smokers (for example, Weber Smokey Mountain).
- 3) Load enough fuel in the smoker.
- 4) If there is a firebox in the smoker, please make sure the wall of the firebox is not blocking the air flow from the blower.
- 5) If you want to reach high temperature, make sure the fuel is raked into a small mound close to the blower.

**10.5 Poor Temperature Control**

If temperature overshoots and stays above your target temperature for long time, probably there is more than enough fresh air gets into the smoker than the what the blower allows. Check if there is any leak from lower vents, the side door, or the lid.

If the temperature gradually drops even when the blower is running, probably the fuel is running low or the fuel is too spread-out.

If the temperature overshoots in the beginning and oscillates constantly, probably the PID setting should be tuned. You can try **P** = 1.8, **I** = 1200, **D** = 70. You'll also need to adjust another parameter SF (under access code 0037, see Appendix 2) and set it to **SF** = 30. Please do NOT change other parameter under this code. This set of parameters should let the pit temperature converge to the target temperature more gently.

If the target temperature is set to lower than 200°F, there is a high chance that the fire will be gone after a while due to the lack for air flow in the smoker.

(End)

**Appendix 1**

Table 4. Other types of thermocouple and their code that can also be used with this controller.

Symbol		Description	Working Temperature Range
<i>t</i>	t	T Thermocouple	-200~400°C; -320~752°F
<i>r</i>	r	R Thermocouple	-50~1600°C; -58~2900°F
<i>J</i>	J	J Thermocouple	-200~1200°C; -320~2200°F
<i>WRE</i>	WRE	TC, WRe3/25	0~2300°C; 32~4200°F
<i>b</i>	b	B Thermocouple	350~1800°C; 660~3300°F
<i>S</i>	S	S Thermocouple	-50~1600°C; -58~2900°F
<i>K</i>	K	K Thermocouple	-200~1300°C; -320~2400°F
<i>E</i>	E	E Thermocouple	-200~900°C; -320~1650°F

**Appendix 2**

Table 5. Control Tuning Parameters (accessed by code 0037).

Symbol		Initial
<i>CatY</i>	CatY	1
<i>SF</i>	SF	20
<i>BB</i>	BB	40
<i>End</i>	End	

**NOTE:** These parameters should not be adjusted user without consulting the technical support from Auber Instruments.

**Auber Instruments Inc.**

5755 North Point Parkway, Suite 99,  
 Alpharetta, GA 30022  
 www.auberins.com

E-mail: info@aubersins.com Tel: 770-569-8420

Copyright 2007-2017, Auber Instruments All Rights Reserved.  
 No part of this manual shall be copied, reproduced, or transmitted in any way without the prior, written consent of Auber Instruments. Auber Instruments retains the exclusive rights to all information included in this document.