

Instruction Manual

TD100 TEMPERATURE CONTROLLER INSTRUCTION MANUAL *Version 1.2*

1. Overview

This temperature controller contains one temperature probe and two independent outputs. One output is for cooling device such as refrigerator and the other one is for heating device. It can be used for applications such as beer fermentation or convert a refrigerator to kegerator. By using both cooling and heating devices, the refrigerator can be controlled at specific temperature regardless in hot summer or cold winter.

This controller is a plug and play controller. No wiring is needed for the heater or cooler. Both the heating and cooling control modes are simple on/off control, similar to a mechanical thermostat but with much higher precision due to adjustable hysteresis band, precise sensor and digital read out. Anti-short function is provided for cooling to protect the compressor from being turned on with high pressure Freon.

Different operation temperature ranges of the two outputs can be set separately. Once the cooling range is set, the controller program will automatically limit the heating range to prevent both heating and cooling from being turned on at the same time.

A digital silicon band gap sensor is used. The advantage is being much more reliable in moisture environment than thermistor sensor. It can be immersed over extended period of time. It also has a more uniform accuracy over an entire specified temperature range.

2. Specification

Temperature Control Range	-50~125 °C, -58~257 °F
Temperature Resolution	0.1 °C (between -9.9 ~ 99 °C) 1 °C (between -50 ~ 10 °C, 100~125°C) 0.1 °F (between -9.9~99.9 °F) 1 °F (between -58 ~ 10 °F, 100 ~257 °F)
Temperature Accuracy	0.5 °C or 0.9 °F
Temperature Control Mode	On/Off Control. Heating and Cooling
Temperature Control Output	10A, 120V or 240V AC *
Audio Alarm	High and Low Limit
Sensor Type	Silicon Band Gap Sensor
Sensor Size	0.25" OD (6.35 mm) x 1" (25mm) long
Sensor Measuring Range	-20~125 °C
Ambient Temperature	-20~ 50 °C
Dimension	91x140x46mm
Input Power	85 ~242VAC, 50Hz/60Hz
Sensor Cable Length	3 ft (1m)
Power Cable Length	3 ft (1m)
Warranty	1 Year

3. Front Panel

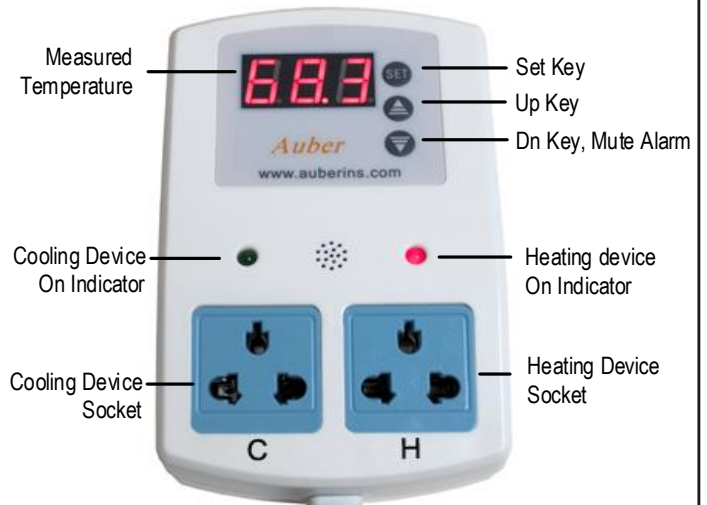

Figure 1. Front Panel

4. Setup Flow Chart

When the controller is powered on, it will display the measured temperature. The controller will keep running according to the saved setting. If the temperature sensor is shorted, the controller will display "Err". Please see Figure 2 for the flow chart to set the parameters.

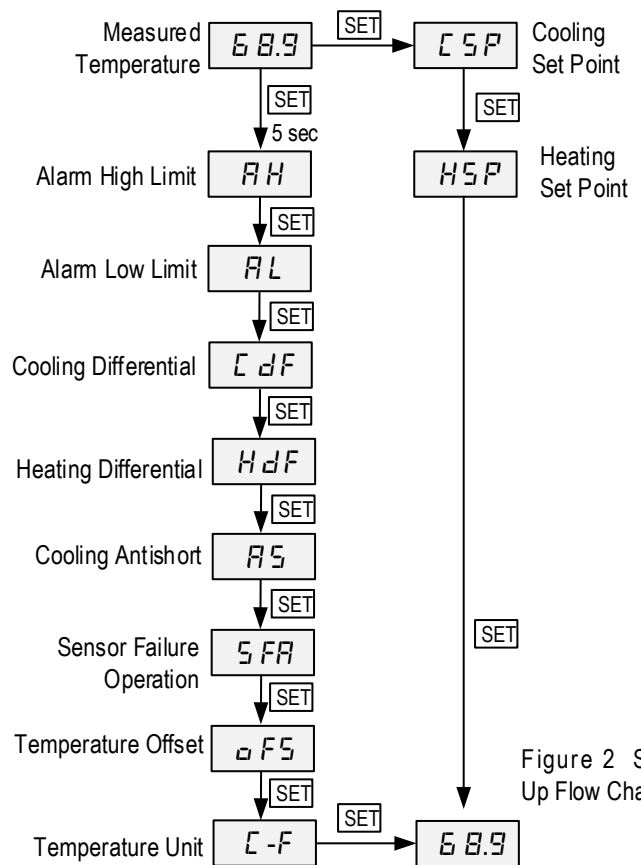

Figure 2 Set Up Flow Chart

5. Parameter Settings

To change the target temperature, press SET key momentarily. The controller will show CSP (Cooling set point), press SET again will show HSP (heating set point). When the controller shows CSP or HSP, use Up or Down key to change the value. Then press SET key to confirm the change.

To change the system parameters, press SET key for 5 seconds, the controller will enter the parameter set up mode. The first parameter AH will show on the display. Use Up or Down key to modify the parameter value. Then press SET key to confirm the change. The display will show the parameter again. Press the SET key to show the next parameter. The instrument will automatically exit if no key is pressed for 10 seconds. Please see the Table 1 for the parameters.

Table 1. Parameters Description

Code	Description	Setting range	Initial	Note
CSP <i>C S P</i>	Cooling Set Point	-58~248 °F -50~125 °C	67.0	1
HSP <i>H S P</i>	Heating Set Point	-58~CSP °F -50~CSP °C	62.0	
AH <i>A H</i>	Alarm High Limit	-58~248 °F -50~125 °C	95.0	2
AL <i>A L</i>	Alarm Low Limit	-58-AH °F -50-AH °C	32	
CdF <i>C d F</i>	Cooling Differential	0~50.0 °F	3.0	1
HdF <i>H d F</i>	Heating Differential	0~50.0 °F	1.0	
AS <i>A S</i>	Cooling Antishort	0~12 min	0	3
SFA <i>S F A</i>	Sensor Failure Operation	0-0, 0-1, 1-0	0-0	4
oFS <i>o F S</i>	Temperature Offset	0~10.0	0	5
C-F <i>C - F</i>	Temperature Unit	C: Celsius F:Fahrenheit	F	

Note 1. For cooling (or heating), the output will be off when the temperature is blow (or over) the set point; will be on again when the temperature rises up (or drops down) to CSP+CdF (or HSP-HdF).

The maximum value of the HSP can be set is the current value of CSP. But CSP can be set to the value between -58~248 °F or -50~125 °C. When the CSP is set to a value lower than current HSP, the HSP will be adjusted to the CSP value automatically.

For example, when CSP=67.0 °F, HSP=62 °F, HSP can be set to any value between -58 and 67.0. For CSP, it can be set to any value between -58 and 248. If you set it to 55.0, the HSP will be set to 55.0 automatically.

Small differential gives tight control; large differential reduces the frequency of cycle on and off. It will extend the life of relay and compressor.

Note 2. When the measured temperature is higher than AH, the high limit alarm will be on; when the measured temperature is lower than AL, the low limit alarm will be on.

When alarm is on, the display will be flashing between the measured value and alarm type. To mute the alarm when it is on, press the Down key momentarily. If the measured value gets out of the alarm zone then gets back to the alarm zone again, the alarm will be on again. To disable the alarm, set AH=AL.

The maximum value of the AL can be set is the current value of AH. But AH can be set to the value between -58~248 °F or -50~125 °C. When AH is set to a value lower than current AL, the AL will be adjusted to the AH value automatically.

For example, when AH=95.0 °F, AL=32 °F, AL can be set to any value between -58 and 95.0. For AH, it can be set to any value between -58 and 248. If you set it to 25.0, the AL will be set to 25.0 automatically.

Note 3. The Cooling Antishort is the delay the time to turn the cooling load on. When the controller is used for cooling and load is a compressor, it should not turn on the compressor when it is at high pressure (just after turned off). Otherwise, It may shorten the life of compressor. The Anti-Short cycle delay function can be used to prevent the rapid cycling of the compressor. It establishes the minimum time that the NO contacts remains open (after reaching cutout) before closing again. The delay overrides any Load Demand and does not allow the NO contacts to close until the set time-delay value has elapsed. It gives time to release the refrigerant pressure through evaporator. It is typically set to 4- 6 (minutes).

Note 4. The SFA defines how the output would be if the sensor fails. It can be set to 0-0, 0-1 or 1-0. Please refer to table 2 for details.

Table 2. Output of the controller when sensor fails:

SFA	Controller output when sensor fails
0-0	cooler off, heater off
1-0	cooler on, heater off
0-1	cooler off, heater on

For example, when the unit controls a refrigerator for food, you may want to set the TSF to ON if the sensor fails to keep the food cold. When it controls a heater, you may want to set the output to OFF for safety purpose .

Note 5. The offset is used to set an input offset to compensate the error produced by the sensor or input signal itself. For example, for temperature, if the unit displays 37 °F when the actual temperature is 32 °F, setting parameter toF= - 5 will make the controller display 32 °F.

6. How to install the sensor to the unit.

The connector of sensor contains a slot for correct pin connection. It also has a spring lock to prevent disconnections from accidental pulling on the cable. To install the to the unit, please align the slot of

the female connector on the sensor to the red mark of the male connector on the unit, then hold the tail and push the female connector forward. To remove the connector, please pull the spring loaded collar of the female connector. Please see the Figure 3 and Figure 4 below for details.



Figure 3. Install the Sensor



Figure 4. Remove the Sensor

Auber Instruments Inc.

5755 North Point Parkway, Suite 99

Alpharetta, GA 30022

www.auberins.com

e-mail: info@auberins.com Tel: 770-569-8420